

CBSE Class 9 Mathemaics
Important Questions
Chapter 13
Surface Areas and Volumes

1 Marks Quetions

1. If the perimeter of one of the faces of a cube is 40 cm, then its volume is

- (a) 6000 cu cm
- (b) 1600 cu cm
- (c) 1000 cu cm
- (d) 600 cu cm

Ans. (c) 1000 cu cm

2. A cuboid having surface areas of 3 adjacent faces as a, b and c has the volume

- (a) $3\sqrt{abc}$
- (b) \sqrt{abc}
- (c) abc
- (d) $a^3 b^3 c^3$

Ans. (b) \sqrt{abc}

3. The diameter of a right circular cylinder is 21 cm and its height is 8 cm. The Volume of the cylinder is

- (a) 528 cu cm
- (b) 1056 cu cm

(c) 1386 cu cm

(d) 2772 cu cm

Ans. (d) 2772 cu cm

4. Each edge of a cube is increased by 40%. The % increase in the surface area is.

(a) 40

(b) 96

(c) 160

(d) 240

Ans. (b) 96

5. Find the curved (lateral) surface area of each of the following right circular cylinders:

(a) $2\pi rh$

(b) πrh

(c) $2\pi r(r + h)$

(d) None of these

Ans. (a) $2\pi rh$

6. The radius and height of a right circular cylinder are each increased by 20%. The volume of cylinder is increased by-

(a) 20%

(b) 40%

(c) 54%

(d) 72.8%

Ans. (d) 72.8%

7. A well of diameter 8 meters has been dug to the depth of 21 m. the volume of the earth dug out is

(a) 1056 cu m

(b) 352 cu m

(c) 1408 cu m

(d) 4224 cu m

Ans. (a) 1056 cu m

8. The radius of a cylinder is doubled and the height remains the same. The ratio between the volumes of the new cylinder and the original cylinder is

(a) 1:2

(b) 1:3

(c) 1:4

(d) 1:8

Ans. (c) 1:4

9. Length of diagonals of a cube of side a cm is

(i) $\sqrt{2}a$ cm

(ii) $\sqrt{3}a$ cm

(iii) $\sqrt{3}a$ cm

(iv) 1 cm



Ans. (ii) $\sqrt{3}a$ cm

10. Surface area of sphere of diameter 14 cm is

(i) 616 cm^2

(ii) 516 cm^2

(iii) 400 cm^2

(iv) 2244 cm^2

Ans. (i) 616 cm^2

11. Surface area of bowl of radius r cm is

(i) $4\pi r^2$

(ii) $2\pi r^2$

(iii) $3\pi r^2$

(iv) πr^2

Ans. (iii) $3\pi r^2$

12. Volume of a sphere whose radius 7 cm is

(i) $1437\frac{1}{3} \text{ cm}^3$

(ii) $1337\frac{1}{3} \text{ cm}^3$

(iii) 1430 cm^3

(iv) 1447 cm^3

Ans. (i) $1437\frac{1}{3} \text{ cm}^3$

13. The curved surface area of a right circular cylinder of height 14 cm is 88 cm^2 . find the diameter of the base of the cylinder

(i) 1 cm

(ii) 2 cm

(iii) 3 cm

(iv) 4 cm

Ans. (ii) 2 cm

14. Volume of spherical shell

(i) $\frac{2}{3} \pi r^3$

(ii) $\frac{3}{4} \pi r^3$

(iii) $\frac{4}{3} \pi [R^3 - r^3]$

(iv) none of these

Ans. (iii) $\frac{4}{3} \pi [R^3 - r^3]$

15. The area of the three adjacent faces of a cuboid are x,y,z. Its volume is V, then

(i) $V = xyz$

(ii) $V^2 = xyz$

(iii) $V = x^2 y^2 z^2$

(iv) none of these

Ans. (ii) $V^2 = xyz$

16. A conical tent is 10 m high and the radius of its base is 24 m then slant height of the tent is

(i) 26

(ii) 27

(iii) 28

(iv) 29

Ans. (i) 26

17. Volume of hollow cylinder

(i) $\pi(R^2 - r^2)h$

(ii) $\pi R^2 h$

(iii) $\pi r^2 h$

(iv) $\pi r^2 (h_1 - h_2)$

Ans. (i) $\pi(R^2 - r^2)h$

18. Diameter of the base of a cone is 10.5 cm and its slant height is 10 cm. then curved surface area.

(i) 155 cm^2

(ii) 165 cm^2

(iii) 150 cm^2

(iv) none of these

Ans. (ii) 165 cm^2

19. The surface area of a sphere of radius 5.6 cm is

(i) $96.8 \pi \text{ cm}^2$

(ii) $94.08 \pi \text{ cm}^2$

(iii) $90.08 \pi \text{ cm}^2$

(iv) none of these

Ans. (ii) $94.08 \pi \text{ cm}^2$

20. The height and the slant height of a cone are 21 cm and 28 cm respectively then volume of cone

(i) 7556 cm^3

(ii) 7646 cm^3

(iii) 7546 cm^3

(iv) none of these

Ans. (c) 7546 cm^3

CBSE Class 9 Mathemaics
Important Questions
Chapter 13
Surface Areas and Volumes

2 Marks Quetions

1. A plastic box 1.5 m long, 1.25 m wide and 65 cm deep is to be made. It is to be open at the top. Ignoring the thickness of the plastic sheet, determine:

(i) The area of the sheet required for making the box.

(ii) The cost of sheet for it, if a sheet measuring 1 m^2 cost Rs. 20.

Ans. (i) Given: Length (l) = 1.5 m, Breadth (b) = 1.25 m and Depth (h) = 65 cm = 0.65 m

Area of the sheet required for making the box open at the top = $2(bh + hl) + lb$

$$= 2(1.25 \times 0.65 + 0.65 \times 1.5) + 1.5 \times 1.25$$

$$= 2(0.8125 + 0.975) + 1.875$$

$$= 2 \times 1.7875 + 1.875$$

$$= 3.575 + 1.875$$

$$= 5.45 \text{ m}^2$$

(ii) Since, Cost of 1 m^2 sheet = Rs. 20

$$\therefore \text{Cost of } 5.45 \text{ m}^2 \text{ sheet} = 20 \times 5.45 = \text{Rs. } 109$$

2. The length, breadth and height of a room are 5 m, 4 m and 3 m respectively. Find the cost of white washing the walls of the room and the ceiling at the rate of Rs. 7.50 per m^2 .



Ans. Given: Length (l) = 5 m, Breadth (b) = 4 m and Height (h) = 3 m

$$\therefore \text{Area of the four walls} = \text{Lateral surface area} = 2(bh + hl) = 2h(b + l)$$

$$= 2 \times 3 (4 + 5)$$

$$= 2 \times 9 \times 3 = 54 \text{ m}^2$$

$$\text{Area of ceiling} = l \times b = 5 \times 4 = 20 \text{ m}^2$$

$$\therefore \text{Total area of walls and ceiling of the room} = 54 + 20 = 74 \text{ m}^2$$

Now Cost of white washing for 1 m^2 = Rs. 7.50

$$\therefore \text{Cost of white washing for } 74 \text{ m}^2 = 74 \times 7.50 = \text{Rs. } 555$$

3. The floor of a rectangular hall has a perimeter 250 m. If the cost of painting the four walls at the rate of Rs. 10 per m^2 is Rs. 15000, find the height of the hall.

Ans. Given: Perimeter of rectangular wall = $2(l + b) = 250 \text{ m}$ (i)

Now Area of the four walls of the room

$$= \frac{\text{Total cost to paint walls of the room}}{\text{Cost to paint } 1 \text{ m}^2 \text{ of the walls}}$$

$$= \frac{15000}{10} = 1500 \text{ m}^2 \text{(ii)}$$

$$\therefore \text{Area of the four walls} = \text{Lateral surface area} = 2(bh + hl) = 2h(b + l) = 1500$$

$$\Rightarrow 250 \times h = 1500 \text{ [using eq. (i) and (ii)]}$$

$$\Rightarrow h = \frac{1500}{250} = 6 \text{ m}$$

Hence required height of the hall is 6 m.

4. The paint in a certain container is sufficient to paint an area equal to 9.375 m^2 . How many bricks of dimensions $22.5 \text{ cm} \times 10 \text{ cm} \times 7.5 \text{ cm}$ can be painted out of this container?

Ans. Given: Length of the brick (l) = 22.5 cm, Breadth (b) = 10 cm and Height (h) = 7.5 m

$$\therefore \text{Surface area of the brick} = 2(lb + bh + hl)$$

$$= 2(22.5 \times 10 + 10 \times 7.5 + 7.5 \times 22.5)$$

$$= 2(225 + 75 + 468.75)$$

$$= 937.5 \text{ cm}^2$$

$$= 0.09375 \text{ m}^2 \text{ [1 cm = 0.01 m]}$$

Now No. of bricks to be painted

$$= \frac{\text{Total area to be painted}}{\text{Area of one brick}}$$

$$= \frac{9.375}{0.09375} = 100$$

Hence 100 bricks can be painted.

5. A cubical box has each edge 10 cm and a cuboidal box is 10 cm wide, 12.5 cm long and 8 cm high.

(i) Which box has the greater lateral surface area and by how much?

(ii) Which box has the smaller total surface area and how much?

Ans. (i) Lateral surface area of a cube = $4(\text{side})^2 = 4 \times (10)^2 = 400 \text{ cm}^2$

Lateral surface area of a cuboid = $2h(l + b) = 2 \times 8(12.5 + 10) = 16 \times 22.5 = 360 \text{ cm}^2$

\therefore Lateral surface area of cubical box is greater by $(400 - 360) = 40 \text{ cm}^2$

(ii) Total surface area of a cube = $6(\text{side})^2 = 6 \times (10)^2 = 600 \text{ cm}^2$

Total surface area of cuboid = $2(lb + bh + hl) = 2(12.5 \times 10 + 10 \times 8 + 8 \times 12.5)$

= $2(125 + 80 + 100)$

= $2 \times 305 = 610 \text{ cm}^2$

∴ Total surface area of cuboid box is greater by $(610 - 600) = 10 \text{ cm}^2$

6. Parveen wanted to make a temporary shelter for her car, by making a box-like structure with tarpaulin that covers all the four sides and the top of the car (with the front face as a flap which can be rolled up). Assuming that the stitching margins are very small and therefore negligible, how much tarpaulin would be required to make the shelter of height 2.5 m with base dimensions 4 m × 3 m ?

Ans. Given: Length of base (l) = 4 m, Breadth (b) = 3 m and Height (h) = 2.5 m

Tarpaulin required to make shelter = Surface area of 4 walls + Area of roof

= $2h(l + b) + lb$

= $2(4 + 3)2.5 + 4 \times 3$

= $35 + 12$

= 47 m^2

Hence 47 m^2 of the tarpaulin is required to make the shelter for the car.

7. The curved surface area of a right circular cylinder of height 14 cm is 88 cm^2 . Find the diameter of the base of the cylinder.

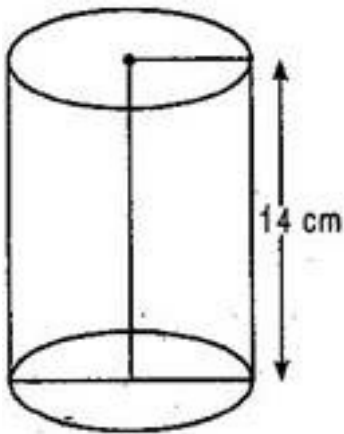

Ans. Given: Height of cylinder (h) = 14 cm, Curved Surface Area = 88 cm^2

Let radius of base of right circular cylinder = r cm

$$2\pi rh = 88$$

$$\Rightarrow 2 \times \frac{22}{7} \times r \times 14 = 88$$

$$\Rightarrow r = 88 \times \frac{7}{22} \times \frac{1}{14} \times \frac{1}{2}$$

$$\Rightarrow r = 1 \text{ cm}$$

Diameter of the base of the cylinder = $2r = 2 \times 1 = 2 \text{ cm}$

8. It is required to make a closed cylindrical tank of height 1 m and base diameter 140 cm from a metal sheet. How many square meters of the sheet are required for the same?

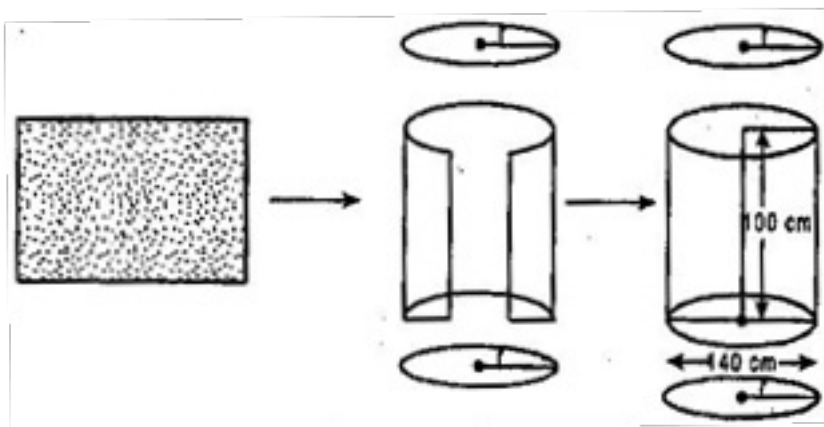

Ans. Given: Diameter = 140 cm

$$\Rightarrow \text{Radius } (r) = 70 \text{ cm} = 0.7 \text{ m}$$

Height of the cylinder (h) = 1 m

$$\text{Total Surface Area of the cylinder} = 2\pi r(r+h) = 2 \times \frac{22}{7} \times 0.7(0.7+1)$$

$$= 2 \times 22 \times 0.7 \times 1.7 = 7.48 \text{ m}^2$$

Hence 7.48 m^2 metal sheet is required to make the close cylindrical tank.

9. The diameter of a roller is 84 cm and its length is 120 cm. It takes 500 complete revolutions to move once over to level a playground. Find the area of the playground in m^2 .

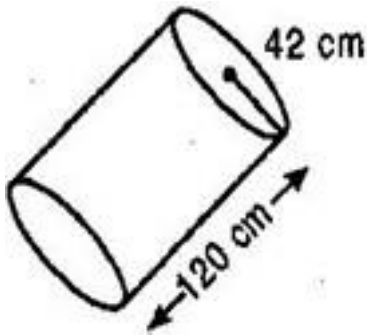

Ans. Diameter of roller = 84 cm

$$\Rightarrow \text{Radius of the roller} = 42 \text{ cm}$$

Length (Height) of the roller = 120 cm

Curved surface area of the roller = $2\pi rh$

$$= 2 \times \frac{22}{7} \times 42 \times 120 = 31680 \text{ cm}^2$$

\therefore Now area leveled by roller in one revolution = 31680 cm^2

\therefore Area leveled by roller in 500 revolutions = $3.1680 \times 500 = 1584.0000 = 1584 \text{ m}^2$

10. A cylindrical pillar is 50 cm in diameter and 3.5 m in height. Find the cost of white washing the curved surface of the pillar at the rate of Rs. 12.50 per m^2 .

Ans. Diameter of pillar = 50 cm

$$\Rightarrow \text{Radius of pillar} = 25 \text{ cm} = \frac{25}{100} = \frac{1}{4} \text{ m}$$

Height of the pillar = 3.5 m

$$\text{Now, Curved surface area of the pillar} = 2\pi rh = 2 \times \frac{22}{7} \times \frac{1}{4} \times 3.5 = \frac{11}{2} m^2$$

\therefore Cost of white washing $1 m^2 = \text{Rs. } 12.50$

$$\therefore \text{Cost of white washing } \frac{11}{2} m^2 = \frac{11}{2} \times 12.50 = \text{Rs. } 68.75$$

11. Curved surface area of a right circular cylinder is $4.4 m^2$. If the radius of the base of the cylinder is 0.7 m, find its height.

Ans. Curved surface area of the cylinder = $4.4 m^2$, Radius of cylinder = 0.7 m

Let height of the cylinder = h

$$\therefore 2\pi rh = 4.4$$

$$\Rightarrow 2 \times \frac{22}{7} \times 0.7 \times h = 4.4$$

$$\Rightarrow h = 4.4 \times 7 \times \frac{1}{22} \times \frac{1}{2}$$

$$\Rightarrow h = 1 \text{ m}$$

12. The inner diameter of a circular well is 3.5 m. It is 10 m deep. Find:

(i) its inner curved surface area.

(ii) the cost of plastering this curved surface at the rate of Rs. 40 per m^2 .

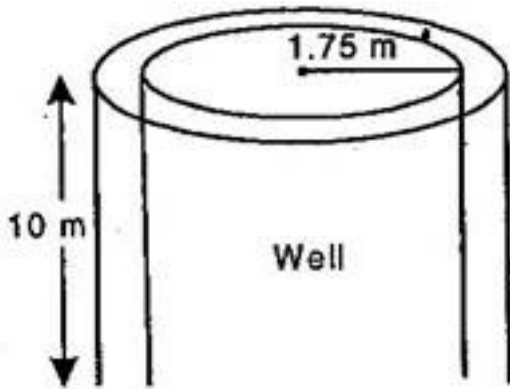

Ans. Inner diameter of circular well = 3.5 m

$$\therefore \text{Inner radius of circular well} = \frac{3.5}{2} = 1.75 \text{ m}$$

And Depth of the well = 10 m

(i) Inner surface area of the well = $2\pi rh$

$$= 2 \times \frac{22}{7} \times 1.75 \times 10 = 110 \text{ m}^2$$

(ii) Cost of plastering 1 m^2 = Rs. 40

$$\text{Cost of plastering } 110 \text{ m}^2 = 40 \times 110 = \text{Rs. } 4400$$

13. In a hot water heating system, there is a cylindrical piping of length 28 m and diameter 5 cm. Find the total radiating surface in the system.

Ans. The length (height) of the cylindrical pipe = 28 m

Diameter = 5 cm

$$\Rightarrow \text{Radius} = \frac{5}{2} \text{ cm}$$

$$\therefore \text{Curved surface area of the pipe} = 2\pi rh = 2 \times \frac{22}{7} \times \frac{5}{2} \times 2800$$

$$= 44000 \text{ cm}^2 = \frac{44000}{10000} = 4.4 \text{ m}^2$$

14. In the adjoining figure, you see the frame of a lampshade. It is to be covered with a decorative cloth. The frame has a base diameter of 20 cm and height of 30 cm. A margin of 2.5 cm is to be given for folding it over the top and bottom of the frame. Find how much cloth is required for covering the lampshade. [See fig.]

Ans. Height of each of the folding at the top and bottom (h) = 2.5 cm

Height of the frame (H) = 30 cm

Diameter = 20 cm

\Rightarrow Radius = 10 cm

Now cloth required for covering the lampshade

= CSA of top part + CSA of middle part + CSA of bottom part

$$= 2\pi rh + 2\pi rH + 2\pi rh$$

$$= 2\pi r(h + H + h)$$

$$= 2\pi r(H + 2h)$$

$$= 2 \times \frac{22}{7} \times 10(30 + 2 \times 2.5)$$

$$= 2200 \text{ cm}^2$$

15. The students of a Vidyalaya were asked to participate in a competition for making and decorating penholders in the shape of a cylinder with a base, using cardboard. Each penholder was to be of radius 3 cm and height 10.5 cm. The Vidyalaya was to



supply the competitors with cardboard. If there were 35 competitors, how much cardboard was required to be bought for the competition?

Ans. Radius of a cylindrical pen holder (r) = 3 cm

Height of the cylindrical pen holder (h) = 10.5 cm

Cardboard required for pen holder = CSA of pen holder + Area of circular base

$$= 2\pi rh + \pi r^2 = \pi r(2h + r)$$

$$= \frac{22}{7} \times 3(2 \times 10.5 + 3) = 226.28 \text{ cm}^2$$

Since Cardboard required for making 1 pen holder = 226.28 cm^2

\therefore Cardboard required for making 35 pen holders = $226.28 \times 35 = 7919.8 \text{ cm}^2$

= 7920 cm^2 (approx.)

16. Diameter of the base of a cone is 10.5 cm and its slant height is 10 cm. Find its curved surface area and its total surface area.

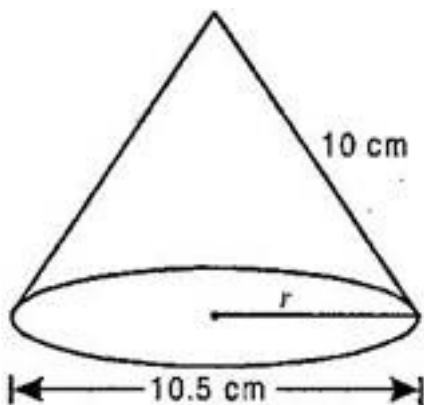

Ans. Diameter = 10.5 cm

$$\Rightarrow \text{Radius } (r) = \frac{10.5}{2} = \frac{21}{4} \text{ cm}$$

Slant height of cone (l) = 10 cm

$$\text{Curved surface area of cone} = \pi r l = \frac{22}{7} \times \frac{21}{4} \times 10$$

$$= 165 \text{ cm}^2$$

$$\text{Total surface area of cone} = \pi r(l+r) = \frac{22}{7} \times \frac{21}{4} \left(10 + \frac{21}{4}\right)$$

$$= \frac{22}{7} \times \frac{21}{4} \times \frac{61}{4} = 251.625 \text{ cm}^2$$

17. Find the total surface area of a cone, if its slant height is 21 cm and diameter of the base is 24 cm.

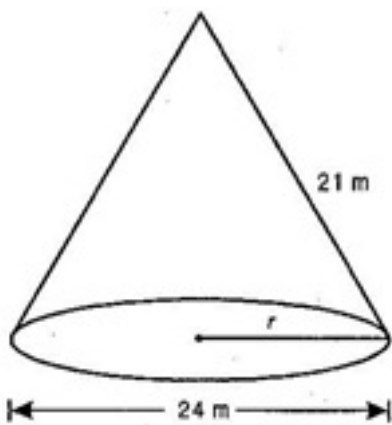

Ans. Slant height of cone (l) = 21 m

Diameter of cone = 24 m

$$\Rightarrow \text{Radius of cone } (r) = \frac{24}{2} = 12 \text{ m}$$

Total surface area of cone = $\pi r(l+r)$

$$= \frac{22}{7} \times 12(21+12)$$

$$= \frac{264}{7} \times 33 = 1244.57 \text{ m}^2$$

18. The slant height and base diameter of a conical tomb are 25 m and 14 m respectively. Find the cost of whitewashing its curved surface at the rate of Rs. 210 per 100 m^2 .

Ans. Slant height of conical tomb (l) = 25 m, Diameter of tomb = 14 m

$$\therefore \text{Radius of the tomb } (r) = \frac{14}{2} = 7 \text{ m}$$

$$\text{Curved surface area of tomb} = \pi r l = \frac{22}{7} \times 7 \times 25 = 550 \text{ m}^2$$

$$\therefore \text{Cost of white washing } 100 \text{ m}^2 = \text{Rs. } 210$$

$$\therefore \text{Cost of white washing } 1 \text{ m}^2 = \frac{210}{100}$$

$$\therefore \text{Cost of white washing } 550 \text{ m}^2 = \frac{210}{100} \times 550 = \text{Rs. } 1155$$

19. A Joker's cap is in the form of a right circular cone of base radius 7 cm and height 24 cm. Find the area of the sheet required to make 10 such caps.

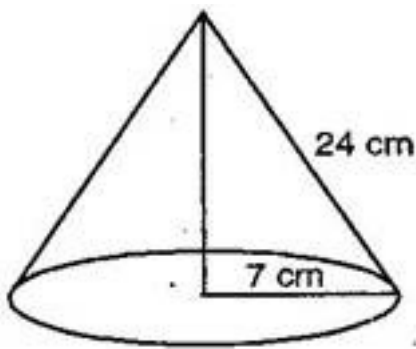

Ans. Radius of cap (r) = 7 cm, Height of cap (h) = 24 cm

$$\text{Slant height of the cone } (l) = \sqrt{r^2 + h^2} = \sqrt{(7)^2 + (24)^2}$$

$$= \sqrt{49 + 576} = \sqrt{625} = 25 \text{ cm}$$

Area of sheet required to make a cap = CSA of cone = πrl

$$= \frac{22}{7} \times 7 \times 25 = 550 \text{ cm}^2$$

\therefore Area of sheet required to make 10 caps = $10 \times 550 = 5500 \text{ cm}^2$

20. Find the surface area of a sphere of radius:

(i) 10.5 cm (ii) 5.6 cm (iii) 14 cm

Ans. (i) Radius of sphere = 10.5 cm

$$\text{Surface area of sphere} = 4\pi r^2 = 4 \times \frac{22}{7} \times 10.5 \times 10.5 = 1386 \text{ cm}^2$$

(ii) Radius of sphere = 5.6 m

$$\text{Surface area of sphere} = 4\pi r^2 = 4 \times \frac{22}{7} \times 5.6 \times 5.6 = 394.84 \text{ m}^2$$

(iii) Radius of sphere = 14 cm

$$\text{Surface area of sphere} = 4\pi r^2 = 4 \times \frac{22}{7} \times 14 \times 14 = 2464 \text{ cm}^2$$

21. Find the surface area of a sphere of diameter:

(i) 14 cm (ii) 21 cm (iii) 3.5 cm

Ans. (i) Diameter of sphere = 14 cm, Therefore Radius of sphere = $\frac{14}{2} = 7 \text{ cm}$

$$\text{Surface area of sphere} = 4\pi r^2 = 4 \times \frac{22}{7} \times 7 \times 7 = 616 \text{ cm}^2$$

(ii) Diameter of sphere = 21 cm

$$\therefore \text{Radius of sphere} = \frac{21}{2} \text{ cm}$$

$$\text{Surface area of sphere} = 4\pi r^2 = 4 \times \frac{22}{7} \times \frac{21}{2} \times \frac{21}{2} = 1386 \text{ cm}^2$$

(iii) Diameter of sphere = 3.5 cm

$$\therefore \text{Radius of sphere} = \frac{3.5}{2} = 1.75 \text{ cm}$$

$$\text{Surface area of sphere} = 4\pi r^2 = 4 \times \frac{22}{7} \times 1.75 \times 1.75 = 38.5 \text{ cm}^2$$

22. Find the total surface area of a hemisphere of radius 10 cm. (Use $\pi = 3.14$)

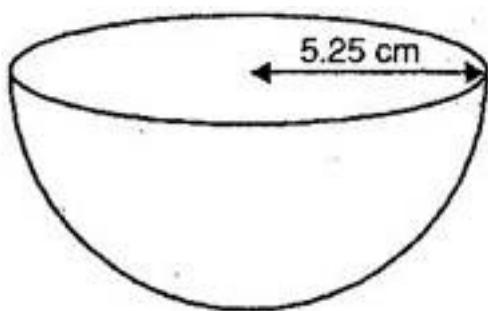

Ans. Radius of hemisphere (r) = 10 cm

$$\text{Total surface area of hemisphere} = 3\pi r^2$$

$$= 3 \times 3.14 \times 10 \times 10$$

$$= 942 \text{ cm}^2$$

Hence total surface area of hemisphere is 942 cm^2 .

23. Find the radius of a sphere whose surface area is 154 cm^2 .

Ans. Surface area of sphere = 154 cm^2

$$\Rightarrow 4\pi r^2 = 154$$



$$\Rightarrow 4 \times \frac{22}{7} \times r^2 = 154$$

$$\Rightarrow r^2 = \frac{154 \times 7}{22 \times 4}$$

$$\Rightarrow r^2 = \frac{49}{4}$$

$$\Rightarrow r = \frac{7}{2} = 3.5 \text{ cm}$$

24. A hemispherical bowl is made of steel, 0.25 cm thick. The inner radius of the bowl is 5 cm. Find the outer curved surface area of the bowl.

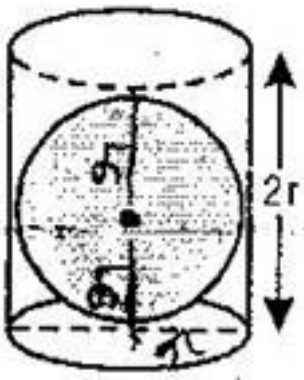

Ans. Inner radius of bowl (r) = 5 cm

Thickness of steel (t) = 0.25 cm

\therefore Outer radius of bowl (R) = $r + t = 5 + 0.25 = 5.25$ cm

\therefore Outer curved surface area of bowl = $2\pi R^2 = 2 \times \frac{22}{7} \times 5.25 \times 5.25$

$$= 2 \times \frac{22}{7} \times \frac{21}{4} \times \frac{21}{4}$$

$$= \frac{693}{4} = 173.25 \text{ cm}^2$$

25. A right circular cylinder just encloses a sphere of radius r (See figure). Find:

- (i) Surface area of the sphere.
- (ii) Curved surface area of the cylinder.
- (iii) Ratio of the areas obtained in (i) and (ii).

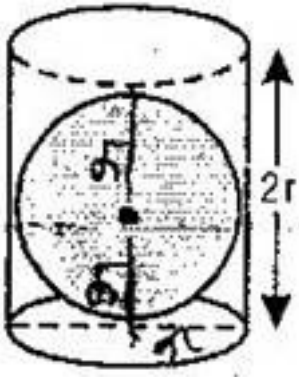

Ans. (i) Radius of sphere = r

∴ Surface area of sphere = $2\pi(\text{radius})^2 = 2\pi r^2$

(ii) ∵ The cylinder just encloses the sphere in it.

∴ The height of cylinder will be equal to diameter of sphere.

And The radius of cylinder will be equal to radius of sphere.

∴ Curved surface area of cylinder = $2\pi r h = 2\pi r \times \pi r$ [$\because h = 2r$]

= $4\pi r^2$

(iii)
$$\frac{\text{Surface area of sphere}}{\text{Curved surface area of cylinder}} = \frac{4\pi r^2}{4\pi r^2} = \frac{1}{1}$$

∴ Required ratio = 1: 1

26. A matchbox $4 \text{ cm} \times 2.5 \text{ cm} \times 1.5 \text{ cm}$. What will be the volume a packet containing 12 such boxes?

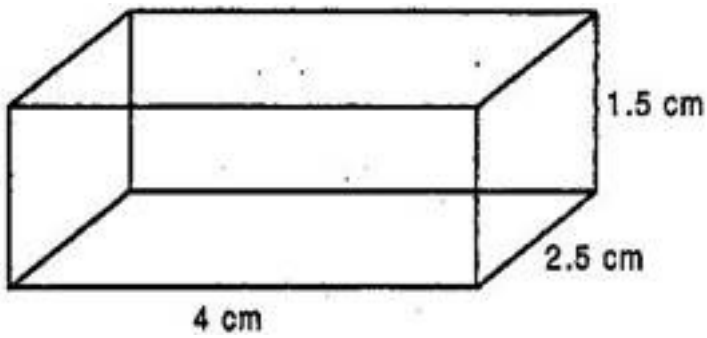

Ans. Given: Length (l) = 4 cm, Breadth (b) = 2.5 cm, Height (h) = 1.5 cm

Volume of a matchbox = $l \times b \times h$

$$= 4 \times 2.5 \times 1.5$$

$$= 15 \text{ cm}^3$$

∴ Volume of a packet containing 12 such

27. A cubical water tank is 6 m long, 5 m wide and 4.5 m deep. How many litres of water can it hold? ($1 \text{ m}^3 = 1000 \text{ l}$)

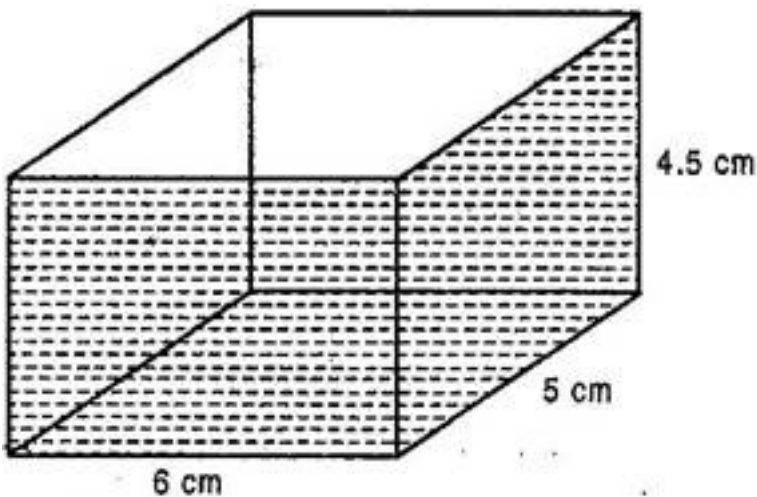

Ans. Volume of water in cuboidal tank

$$= 6 \text{ m} \times 5 \text{ m} \times 4.5 \text{ m}$$

$$= 135 \text{ m}^3$$

$$= 135 \times 1000 \text{ liters}$$

= 135000 liters

Hence tank can hold 135000 liters of water.

28. A cuboidal vessel is 10 m long and 8 m wide. How high must it be to hold 380 cubic meters of a liquid?

Ans. Let height of cuboidal vessel = h m

Volume of liquid in cuboidal vessel = 380 m^3

$$\Rightarrow l \times b \times h = 380 \text{ m}^3$$

$$\Rightarrow 10 \text{ m} \times 8 \text{ m} \times h = 380$$

$$\Rightarrow h = \frac{380}{10 \times 8} = 4.75 \text{ m}$$

Hence cuboidal vessel is 4.75 m high.

29. Find the cost of digging a cuboidal pit 8 m long, 6 m broad and 3 m deep at the rate of Rs. 30 per m^3 .

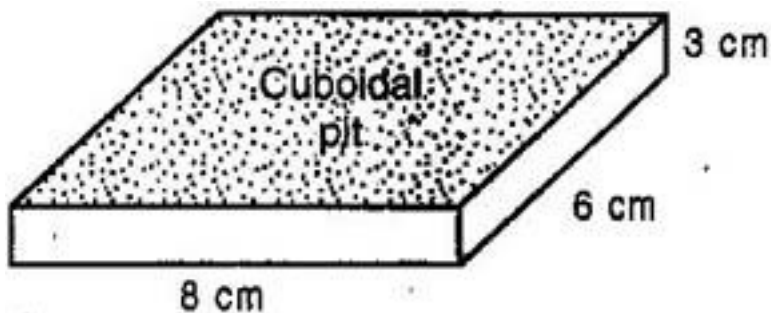

Ans. Volume of cuboidal pit = $8 \text{ m} \times 6 \text{ m} \times 3 \text{ m}$

$$= 144 \text{ m}^3$$

\therefore Cost of digging 1 m^3 cuboidal pit = Rs. 30

\therefore Cost of digging 144 m^3 cuboidal pit

$$= 30 \times 144$$

$$= \text{Rs. } 4320$$

30. The capacity of a cuboidal tank is 50000 litres of water. Find the breadth of the tank, if its length and depth are respectively 2.5 m and 10 m. ($1 \text{ m}^3 = 1000 \text{ l}$)

Ans. Capacity of cuboidal tank = 50000 liters

$$\Rightarrow l \times b \times h = 50000 \text{ liters}$$

$$\Rightarrow 2.5 \text{ m} \times b \times 10 \text{ m} = \frac{50000}{1000} \text{ m}^3 \left[\because 1000 \text{ l} = 1 \text{ m}^3 \right]$$

$$\Rightarrow 25 \times b = 50$$

$$\Rightarrow b = 2 \text{ m}$$

Hence breadth of cuboidal tank is 2 m.

31. A river 3 m deep and 40 m wide is flowing at the rate of 2 km per hour. How much water will fall into the sea in a minute?

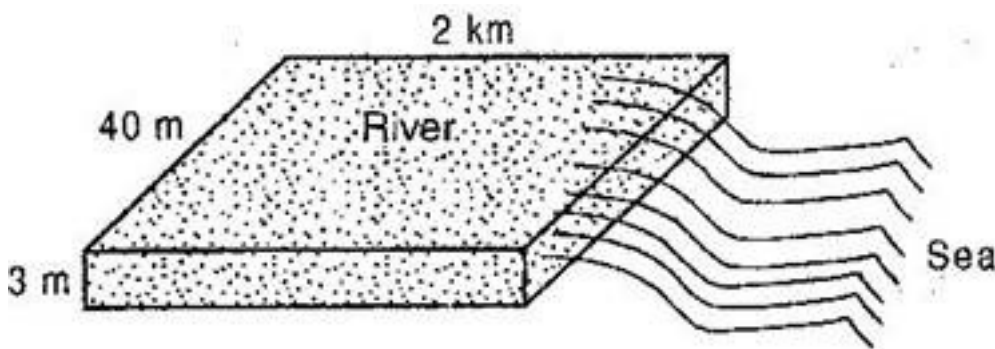

Ans. Since water flows at the rate of 2 km per hour, the water from 2 km of the river flows into the sea in one hour.

Therefore, the volume of water flowing into the sea in one hour = Volume of a cuboid

$$= l \times b \times h = 2000 \text{ m} \times 40 \text{ m} \times 3 \text{ m}$$

$$= 240000 \text{ m}^3 \text{ [1 km = 1000 m]}$$

Now, Volume of water flowing into sea in 1 hour (in 60 minutes) = 240000 m^3

$$\therefore \text{Volume of water flowing into sea in 1 minute} = \frac{240000}{60} = 4000 \text{ m}^3$$

32. Find the length of a wooden plank of width 2.5 m, thickness 0.025 m and volume 0.25 m^3 .

Ans. Given: Volume of wooden plank = 0.25 m^3

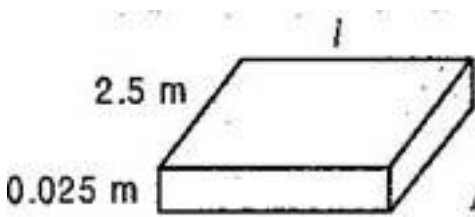

$$\Rightarrow l \times 2.5 \times 0.025 = 0.25$$

$$\Rightarrow l = \frac{0.25}{2.5 \times 0.025}$$

$$\Rightarrow l = 4 \text{ m}$$

Hence required length of wooden plank is 4 m.

33. If the lateral surface of a cylinder is 94.2 cm^2 and its height is 5 cm, then (i) radius of its base (ii) volume of the cylinder.

Ans. Height of the cylinder (h) = 5 cm

Lateral surface area of the cylinder = 94.2 cm^2

$$\Rightarrow 2\pi rh = 94.2$$

$$\Rightarrow 2 \times 3.14 \times r \times 5 = 94.2$$

$$\Rightarrow r = \frac{94.2}{2 \times 3.14 \times 5} = 3 \text{ cm}$$

$$\therefore \text{Volume of cylinder} = \pi r^2 h = 3.14 \times 3 \times 3 \times 5 = 141.3 \text{ cm}^3$$

34. A bag of grain contains 2.8 m^3 of grain. How many bags are needed to fill a drum of radius 4.2 m and height 5 m?

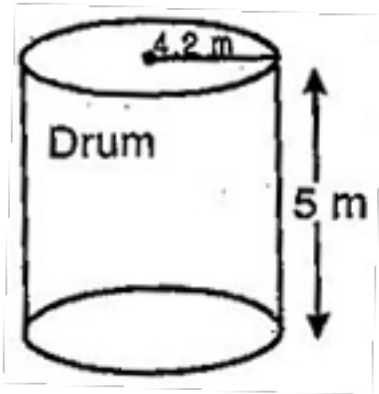

Ans. Radius of drum (r) = 4.2 m and Height of drum (h) = 5 m

$$\text{Volume of a drum} = \pi r^2 h = \frac{22}{7} \times 4.2 \times 4.2 \times 5$$

$$= 22 \times 0.6 \times 4.2 \times 5 = 277.2 \text{ m}^3$$

$$\text{Now, Number of bags} = \frac{\text{Volume of grain in the drum}}{\text{Volume of each bag}}$$

$$= \frac{277.2}{2.8}$$

$$= 99$$

Hence 99 bags are needed to fill the drum.

35. A lead pencil consists of a cylinder of wood with a solid cylinder of graphite filled in the interior. The diameter of the pencil is 7 mm and diameter of graphite is 1 mm. If the length of the pencil is 14 cm, find the columns of the wood and that of the graphite.

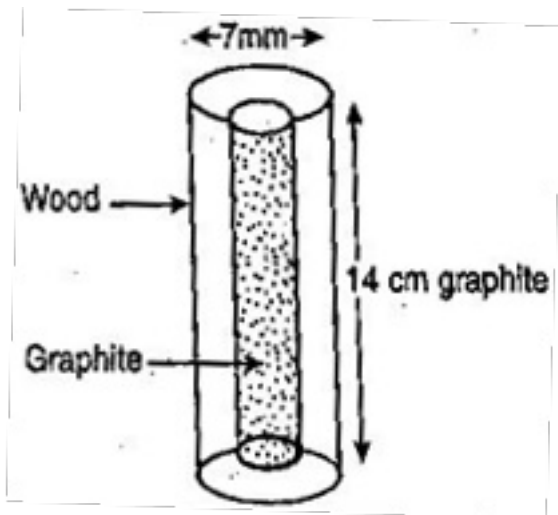

Ans. Diameter of graphite = 1 mm

∴ Radius of drum = 0.5 mm = 0.05 cm

Height of graphite (h) = 14 cm

$$\text{Volume of graphite} = \pi r^2 h = \frac{22}{7} \times (0.05)^2 \times 14 = 0.11 \text{ cm}^3$$

Diameter of pencil = 7 mm

∴ Radius of pencil (R) = 3.5 mm = 0.35 cm

$$\text{Volume of pencil} = \pi R^2 h = \frac{22}{7} \times (0.35)^2 \times 14 = 5.39 \text{ cm}^3$$

Now, Volume of wood = Volume of pencil – Volume of graphite

$$= 5.39 - 0.11 = 5.28 \text{ cm}^3$$

CBSE Class 9 Mathemaics
Important Questions
Chapter 13
Surface Areas and Volumes

2 Marks Quetions

36. A patient in a hospital is given soup daily in a cylindrical bowl of diameter 7 cm. If the bowl is filled with soup to a height of 4 cm, how much soup the hospital has to prepare daily to serve 250 patients?

Ans. Diameter of circular base of cylindrical bowl = 7 cm

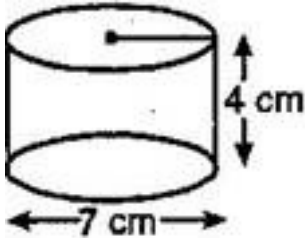

∴ Radius of circular base of cylindrical bowl (r) = $\frac{7}{2}$ cm

Height of the bowl (h) = 4 cm

Now, Volume of cylindrical bowl = $\pi r^2 h$

$$= \frac{22}{7} \times \frac{7}{2} \times \frac{7}{2} \times 4 = 22 \times 7 = 154 \text{ cm}^3$$

∴ Quantity of soup filled in a bowl = 154 cm^3

Therefore, total quantity of soup to be prepared by the hospital = 250×154

$$= 38500 \text{ cm}^3$$

$$= \frac{38500}{1000} \text{ liter } [\because 1 \text{ liter} = 1000 \text{ cm}^3]$$

$$= 38.5 \text{ liters}$$

37. Find the volume of the right circular cone with:

(i) Radius 6 cm, Height 7 cm

(ii) Radius 3.5 cm, Height 12 cm

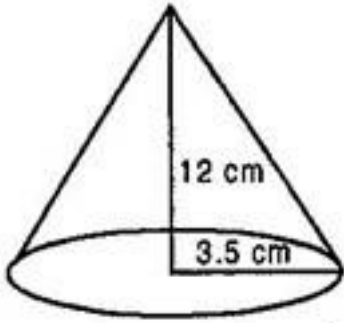

Ans. (i) Given: $r = 6$ cm, $h = 7$ cm

$$\text{Volume of cone} = \frac{1}{3} \pi r^2 h$$

$$= \frac{1}{3} \times \frac{22}{7} \times 6 \times 6 \times 7$$

$$= 264 \text{ cm}^3$$

(ii) Given: $r = 3.5$ cm, $h = 12$ cm

$$\text{Volume of cone} = \frac{1}{3} \pi r^2 h$$

$$= \frac{1}{3} \times \frac{22}{7} \times 3.5 \times 3.5 \times 12$$

$$= 154 \text{ cm}^3$$

38. The height of a cone is 15 cm. If its volume is 1570 cm^3 , find the radius of the base.

(Use $\pi = 3.14$)

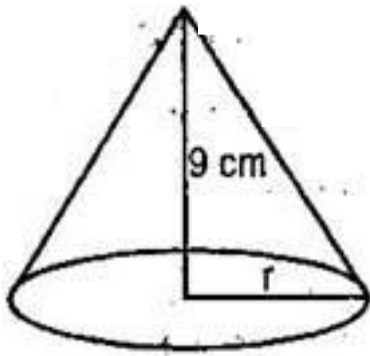

Ans. Height of the cone (h) = 15 cm

Volume of cone = 1570 cm^3

$$\Rightarrow \frac{1}{3} \pi r^2 h = 1570$$

$$\Rightarrow \frac{1}{3} \times \frac{22}{7} \times r^2 \times 15 = 1570$$

$$\Rightarrow 15.70 r^2 = 1570$$

$$\Rightarrow r^2 = 1570 \times \frac{100}{1570} = 100$$

$$\Rightarrow r = 10 \text{ cm}$$

Hence required radius of the base is 10 cm.

39. If the volume of a right circular cone of height 9 cm is $48\pi \text{ cm}^3$, find the diameter of the base.

Ans. Height of the cone (h) = 9 cm

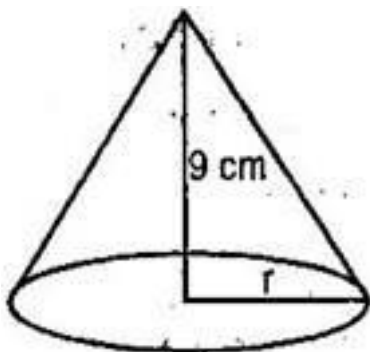

$$\text{Volume of cone} = 48\pi\text{m}^3$$

$$\Rightarrow \frac{1}{3}\pi r^2 h = 48\pi$$

$$\Rightarrow \frac{1}{3}\pi r^2 \times 9 = 48\pi$$

$$\Rightarrow 3r^2 = 48$$

$$\Rightarrow r^2 = \frac{48}{3} = 16$$

$$\Rightarrow r = 4 \text{ cm}$$

$$\therefore \text{Diameter of base} = 2r = 2 \times 4 = 8 \text{ cm}$$

40. A conical pit of top diameter 3.5 m is 12 m deep. What is its capacity in kiloliters?

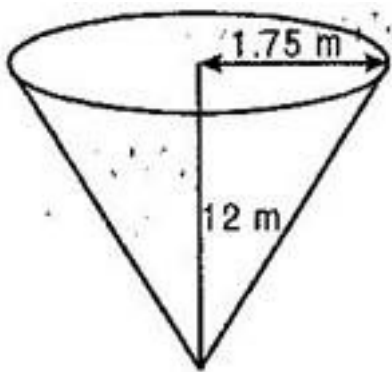

Ans. Diameter of pit = 3.5 m

$$\therefore \text{Radius of pit} = \frac{3.5}{2} = 1.75 \text{ m}$$

Depth of pit (h) = 12 m

$$\text{Capacity of pit} = \frac{1}{3}\pi r^2 h$$

$$= \frac{1}{3} \times \frac{22}{7} \times 1.75 \times 1.75 \times 12$$



$$\begin{aligned}
&= \frac{1}{3} \times \frac{22}{7} \times \frac{175}{100} \times \frac{175}{100} \times 12 \\
&= \frac{1}{3} \times \frac{22}{7} \times \frac{7}{4} \times \frac{7}{4} \times 12 \\
&= 22 \times \frac{7}{4} = \frac{77}{2} m^3 = 35.8 m^3
\end{aligned}$$

$$= 38.5 \text{ kl} [\because 1 m^3 = 1 \text{ kl}]$$

41. A right triangle ABC with sides 5 cm, 12 cm and 13 cm is revolved about the side 12 cm. Find the volume of the solid so obtained. (Use $\pi = 3.14$)

Ans. When right angled triangle ABC is revolved about side 12 cm, then the solid formed is a cone.

In that cone, Height (h) = 12 cm

And radius (r) = 5 cm

Therefore, Volume of cone = $\frac{1}{3} \pi r^2 h$

$$= \frac{1}{3} \pi \times 5 \times 5 \times 12$$

$$= 100\pi cm^3$$

42. Find the volume of the largest right circular cone that can be fitted in a cube whose edge is 14 cm.

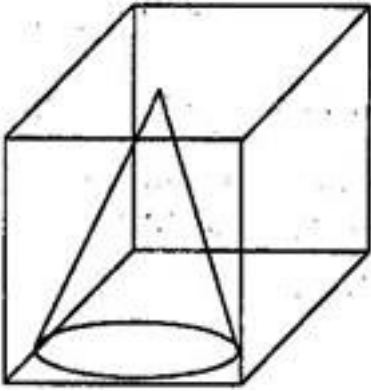

Ans. Since, diameter of the largest right circular cone that can be fitted in a cube = Edge of cube

$$\Rightarrow 2r = 14 \text{ cm}$$

$$\Rightarrow r = 7 \text{ cm}$$

And also Height of the cone (h) = Edge of cube = 14 cm

$$\text{Now, Volume of the largest cone} = \frac{1}{3} \pi r^2 h$$

$$= \frac{1}{3} \times \frac{22}{7} \times 7 \times 7 \times 14$$

$$= \frac{22 \times 7 \times 14}{3}$$

$$= \frac{2156}{3} = 718.66 \text{ cm}^3$$

43. Find the volume of a sphere whose radius is (i) 7 cm and (ii) 0.63 cm.

Ans. (i) Radius of sphere (r) = 7 cm

$$\text{Volume of sphere} = \frac{4}{3} \pi r^3$$

$$= \frac{4}{3} \times \frac{22}{7} \times 7 \times 7 \times 7$$



$$= \frac{4312}{3} = 1437\frac{1}{3} \text{ cm}^3$$

(ii) Radius of sphere (r) = 0.63 m

$$\text{Volume of sphere} = \frac{4}{3} \pi r^3$$

$$= \frac{4}{3} \times \frac{22}{7} \times 0.63 \times 0.63 \times 0.63$$

$$= \frac{4}{3} \times \frac{22}{7} \times \frac{63}{100} \times \frac{63}{100} \times \frac{63}{100}$$

$$= 1.047816 \text{ m}^3 = 1.05 \text{ m}^3 \text{ (approx.)}$$

44. Find the amount of water displaced by a solid spherical ball of diameter:

(i) 28 cm (ii) 0.21 m

Ans. (i) Diameter of spherical ball = 28 cm

$$\therefore \text{Radius of spherical ball } (r) = \frac{28}{2} = 14 \text{ cm}$$

According to question, Volume of water replaced = Volume of spherical ball = $\frac{4}{3} \pi r^3$

$$= \frac{4}{3} \times \frac{22}{7} \times 14 \times 14 \times 14$$

$$= \frac{34496}{3} = 11498\frac{2}{3} \text{ cm}^3$$

(ii) Diameter of spherical ball = 0.21 m

$$\therefore \text{Radius of spherical ball } (r) = \frac{0.21}{2} \text{ m}$$



According to question,

$$\text{Volume of water replaced} = \text{Volume of spherical ball} = \frac{4}{3} \pi r^3$$

$$= \frac{4}{3} \times \frac{22}{7} \times \frac{0.21}{2} \times \frac{0.21}{2} \times \frac{0.21}{2}$$

$$= \frac{4}{3} \times \frac{22}{7} \times \frac{21}{200} \times \frac{21}{200} \times \frac{21}{200}$$

$$= 11 \times \frac{441}{100 \times 100 \times 100} = 0.004851 \text{ m}^3$$

45. The diameter of a metallic ball is 4.2 cm. What is the mass of the ball, if the metal weighs 8.9 g per cm^3 ?

Ans. Diameter of metallic ball = 4.2 cm

$$\therefore \text{Radius of metallic ball } (r) = \frac{4.2}{2} = 2.1 \text{ cm}$$

$$\text{Volume of metallic ball} = \frac{4}{3} \pi r^3$$

$$= \frac{4}{3} \times \frac{22}{7} \times 2.1 \times 2.1 \times 2.1$$

$$= \frac{4}{3} \times \frac{22}{7} \times \frac{21}{10} \times \frac{21}{10} \times \frac{21}{10} = 38.808 \text{ cm}^3$$

Density of metal = 8.9 g per cm^3

$$\therefore \text{Mass of } 1 \text{ cm}^3 = 8.9 \text{ g}$$

$$\therefore \text{Mass of } 38.808 \text{ cm}^3 = 8.9 \times 38.808 = 345.3912 \text{ g} = 345.39 \text{ g (approx.)}$$

46. A hemispherical tank is made up of an iron sheet 1 cm thick. If the inner radius is 1

m, then find the volume of the iron used to make the tank.

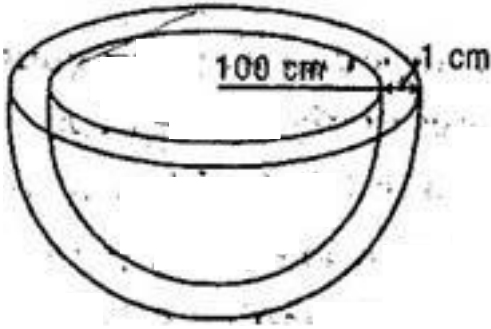

Ans. Inner radius of hemispherical tank (r) = 1 m = 100 cm

Thickness of sheet = 1 cm

∴ Outer radius of hemispherical tank (R) = 100 + 1 = 101 cm

$$\text{Volume of iron of hemisphere} = \frac{2}{3} \pi [R^3 - r^3]$$

$$= \frac{2}{3} \times \frac{22}{7} \times [(101)^3 - (100)^3]$$

$$= \frac{44}{21} [1030301 - 1000000]$$

$$= 0.06348 \text{ m}^3$$

47. A dome of a building is in the form of a hemisphere. From inside, it was white-washed at the cost of Rs. 498.96. If the cost of white-washing is at the rate of Rs. 2.00 per square meter, find:

(i) the inner surface area of the dome.

(ii) the volume of the air inside the dome.

Ans. Cost of white washing from inside = Rs. 498.96

Rate of white washing = Rs. 2

$$\therefore \text{Area white washed} = \frac{498.96}{2} = 249.48 \text{ cm}^2$$

Inside surface area of the dome = 249.48 cm^2

$$\Rightarrow 2\pi r^2 = 249.48$$

$$\Rightarrow r^2 = \frac{249.48 \times 7}{2 \times 22} = 5.67 \times 7$$

$$\Rightarrow r = 6.3$$

So, Volume of the dome = $\frac{2}{3}\pi r^3$

$$= \frac{2}{3} \times \frac{22}{7} \times 6.3 \times 6.3 \times 6.3$$

$$= 523.9 \text{ cm}^3$$

48. Twenty-seven solid iron spheres, each of radius r and surface area S are melted to form a sphere with surface area S' . Find the:

(i) radius r' of the new sphere.

(ii) ratio of S and S' .

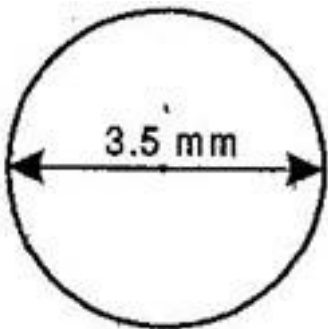

Ans. (i) Let radius of sphere be r and radius of new sphere be R .

$27 \times$ Volume of sphere = Volume of new sphere

$$\Rightarrow 27 \times \frac{4}{3}\pi r^3 = \frac{4}{3}\pi R^3$$

$$\Rightarrow \sqrt[3]{27 \times r^3} = R$$

$$\Rightarrow 3r = R$$

$$(ii) \frac{\text{Surface area of sphere (S)}}{\text{Surface area of sphere (S')}} = \frac{4\pi r^2}{4\pi R^2} = \frac{r^2}{R^2} = \frac{r^2}{(3r)^2}$$

$$= \frac{r^2}{9r^2} = \frac{1}{9}$$

$$= \frac{r^2}{9r^2} = \frac{1}{9}$$

49. a capsule of medicine is in the shape of a sphere of diameter 3.5 mm. How much medicine (in mm^3) is needed to fill this capsule?

Ans. Diameter of spherical capsule = 3.5 mm

$$\therefore \text{Radius of spherical capsule } (r) = \frac{3.5}{2} = \frac{35}{20} = \frac{7}{4} \text{ mm}$$

Medicine needed to fill the capsule = Volume of sphere

$$= \frac{4}{3} \pi r^3 = \frac{4}{3} \times \frac{22}{7} \times \frac{7}{4} \times \frac{7}{4} \times \frac{7}{4}$$

$$= \frac{11 \times 7 \times 7}{3 \times 2 \times 4} = \frac{539}{24} \text{ mm}^3$$

$$= 22.46 \text{ mm}^3 \text{ (Approx.)}$$

50. Sameera wants to celebrate the fifth birthday of her daughter with a party. She bought thick paper to make the conical party caps. Each cap is to have a base diameter of 10 cm and height 12 cm. A sheet of the paper is 25 cm by 40 cm and approximately 82% of the sheet can be effectively used for making the caps after cutting. What is the minimum number of sheets of paper that Sameera would need to buy, if there are to be 15 children at the party? (Use $\pi = 3.14$)

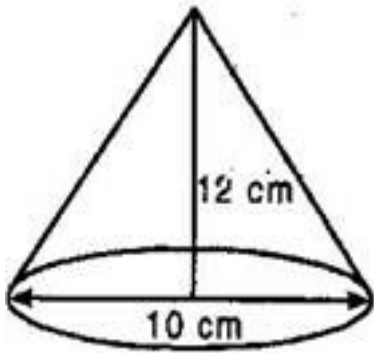

Ans. Diameter of base of conical cap = 10 cm

∴ Radius of conical cap (r) = 5 cm

Slant height of cone (l) = $\sqrt{r^2 + h^2}$

$$= \sqrt{(5)^2 + (12)^2}$$

$$= \sqrt{25 + 144} = \sqrt{169} = 13 \text{ cm}$$

Curved surface area of a cap = πrl

$$= 3.14 \times 5 \times 13 = 204.1 \text{ cm}^2$$

Curved surface area of 15 caps = $15 \times 204.1 = 3061.5 \text{ cm}^2$

Area of a sheet of paper used for making caps = $25 \times 40 = 1000 \text{ cm}^2$

82% of sheet is used after cutting = 82% of 1000 cm^2

$$= \frac{82}{100} \times 1000 = 820 \text{ cm}^2$$

$$\text{Number of sheet} = \frac{3061.5}{820} = 3.73$$

Hence 4 sheets area needed.

51. Curved surface area of a right circular cylinder is 4.4 sq m. if the radius of the base of the cylinder is 0.7 m find its height.

Ans. Curved surface area of the cylinder = 4.4sq.m

Radius of the cylinder = 0.7m

Let h be the height of the cylinder

$$\therefore \text{Curved surface area of the cylinder} = 2\pi rh$$

$$2\pi rh = 4.4$$

or,

$$2 \times \frac{22}{7} \times 0.7 \times h = 4.4$$

$$h = \frac{4.4 \times 7}{2 \times 22 \times 0.7} m$$

$$= \frac{44 \times 7}{44 \times 7} m$$

$$= 1m$$

Hence the height of the cylinder = 1m

52. The circumference of the trunk of a tree (cylindrical), is 44dm. Find the volume of the timber obtained from the trunk if the length of the trunk is 5 m. ($\pi = \frac{22}{7}$).

Ans. Let r be the radius of the cylindrical Trunk

Circumference of the trunk = 44dm

$$\therefore 2\pi r = 44$$

$$2 \times \frac{22}{7} \times r = 44$$

$$\therefore r = \frac{44 \times 7}{2 \times 22} m$$

$$r = 7 \text{ dm} \Rightarrow \frac{7}{10} \text{ m}$$

∴ Volume of the timber = $\pi r^2 h$ cm unit

$$= \left(\frac{22}{7} \times \frac{7}{10} \times \frac{7}{10} \times 5 \right) \text{ cu m}$$

$$= \frac{770}{100} \text{ cu m}$$

$$= 7.7 \text{ cu m}$$

53. If the areas of three adjacent faces of a cuboids are X, Y and Z. If its volume is V, prove that $V^2 = XYZ$

Ans. Let length, breadth and height of the cuboid l, b and h respectively

$$\therefore v = lbh \text{ (i)}$$

Again,

$$x = lb$$

$$y = bh$$

$$\text{and } z = hl$$

$$\therefore xyz = (lb) (bh) (hl)$$

$$= l^2 b^2 h^2$$

$$= (lbh)^2$$

$$= v^2 \text{ [Using (i)]}$$

$$\text{Hence, } v^2 = xyz$$



54. Find the volume of an iron bar has in the shape of cuboids whose length, breadth and height measure 25 cm. 18 cm and 6 cm respectively. Find also its weight in kilograms if 1 cu cm of iron weight 100 grams.

Ans. Length of the bar = 25 cm

Breadth of the bar = 18 cm

Height of the bar = 6 cm

∴ Volume of the iron bar = $l \times b \times h$ cu unit

$$= (25 \times 18 \times 6) \text{ cu cm}$$

$$= 2700 \text{ cu cm}$$

$$\text{Weight of the bar} = (2700 \times 100) \text{ gm}$$

$$= 270000 \text{ gm}$$

$$= 270 \text{ kg}$$

55. A rectangular piece of paper is 22cm long and 12cm wide. A cylinder is formed by rolling the paper along its length. Find the volume of the cylinder.

Ans. It is clear that circumference of the base of the cylinder = length of the paper

Let r cm be the radius of the base of the cylinder and its height as h cm.

$$\therefore 2\pi r = 22 \text{ and } h = 12 \text{ cm}$$

$$\text{or } 2 \times \frac{22}{7} \times r = 22$$

$$\therefore r = \frac{7}{2} \text{ cm}$$

$$\therefore \text{volume of the cylinder} = \pi r^2 h \text{ cu units}$$

$$= \frac{22}{7} \times \left(\frac{7}{2}\right)^2 \times 12 \text{ cu cm}$$

$$= \frac{22 \times 7 \times 7 \times 12}{7 \times 2 \times 2} \text{ cu cm}$$

=462 cu cm.

56. If the radius of the base of a right circular cylinder is halved, keeping the height same, find the ratio of the volume of the reduced cylinder to that of original cylinder.

Ans. Let the radius of the original cylinder = r units

Height of the original cylinder = h units

$$\therefore \text{volume of the cylinder} = \pi r^2 h \text{ cu units} \rightarrow (i)$$

$$\text{Radius of the reduced cylinder} = \frac{r}{2} \text{ units}$$

Height of the reduced cylinder = h units

$$\therefore \text{volume of the cylinder} = \pi \left(\frac{r}{2}\right)^2 h \text{ cu units}$$

$$= \frac{\pi r^2 h}{4} \text{ cu units} \rightarrow (2)$$

From (i) and (ii) we get

$$\frac{\text{volume of cylinder (reduced)}}{\text{volume of the original cylinder}} = \frac{\pi r^2 h}{\pi r^2 h}$$

$$= \frac{1}{4}$$

Thus there required ratio = 1:4

57. A rectangle tank measuring 5m by 4.5m by 2.1m is dug in the centre of a field 25m by 13.5m. The earth dug out is spread evenly over the remaining portion of the field. How much is the level of the field raised?

Ans. Volume of the tank = $5 \times 4.5 \times 2.1 \text{ cu m}$

= 47.25 cu m

∴ Volume of the earth dug = 47.25 cu m

Area of the field = 25×13.5

= 337.5 sq m

∴ Remaining area of the field = (337.5 - 47.25)

= 290.25 sq m

∴ Level of the field raised = $\frac{\text{volume of the earth dug out}}{\text{remaining area of the field}}$

= $\frac{47.25}{290.25} \text{ m} = \frac{4725}{29025} \text{ cm}$

= 15 cm

58. A village having a population of 4000 requires 150 litres of water per head per day. It has a water tank measuring $20\text{m} \times 15\text{m} \times 6\text{m}$ which is full of water. For how many days will the water tank last?

Ans. Volume of water sufficient for 4000 persons for a day.

$4000 \times 150 \text{ litres} = \frac{4000 \times 150}{1000} \text{ cu m}$

= 600 cu m

Volume of water in the tank = $20 \times 15 \times 6 \text{ cu m}$

∴ number of days for which the water

$$\text{Will last} = \frac{20 \times 15 \times 6}{600} = 3$$

Hence the water last for 3 days.

59. Find the curved surface area of a right circular cone whose slant height is 10 cm and base radius is 7 cm

$$\text{Ans. Curved surface area } \pi r l = \frac{22}{7} \times 7 \times 10 \text{ cm}^2 = 220 \text{ cm}^2$$

60. Find (i) the curved surface area and (ii) Total surface area of a hemisphere of radius 21 cm

$$\text{Ans. (i) The curved surface area of hemisphere of radius 21cm would be } = 2\pi r^2$$

$$= 2 \times \frac{22}{7} \times 21 \times 21 \text{ cm}^2 = 2772 \text{ cm}^2$$

$$\text{(ii) The total surface area of the hemisphere} = 3\pi r^2 = 3 \times \frac{22}{7} \times 21 \times 21 \text{ cm}^2$$

$$= 4158 \text{ cm}^2$$

61. The circumference of the base of a cylindrical vessel is 132 cm and its height is 25 cm. How many litres of water can it hold? [1000 cm³ = 1l]

Ans. Given circumference of base of cylindrical vessel = 132cm

$$2\pi r = 132 \text{ cm}$$

$$r = \frac{132}{2\pi} = \frac{66}{\cancel{2} \times \cancel{7}} \times 7 = 21 \text{ cm}$$

$$h = 25\text{cm}$$

$$\text{Volume of vessel} = \pi r^2 h$$

$$= \frac{22}{7} \times 21 \times 21 \times 25 = 34650\text{cm}^3$$

$$= \frac{34650}{1000} \text{ l}$$

$$= 34.65 \text{ l}$$

62. A cubical box has each edge 10 cm and another cuboidal box is 12.5 cm long, 10 cm wide and 8 cm high. Which box has the greater lateral surface area and by how much?

Ans. Side of cubical box = 10cm

$$\text{Lateral surface area of cube} = 4a^2$$

$$4 \times 10^2 = 400\text{cm}^2$$

Length of cuboidal box = 12.5cm.

Breadth = 10cm

Height = 8cm

$$\text{Lateral surface area} = 2[l + b]h$$

$$= 2[12.5 + 10]8$$

$$= 16 \times 22.5 = 360\text{cm}^2$$

$$\text{Difference} = 400 - 360 = 40\text{cm}^2$$

Lateral surface area of cuboidal box is greater by 40cm^2

63. A hemi spherical bowl has a radius of 3.5 cm. What would be the volume of water it



would contain?

Ans. The volume of water the bowl contain = $\frac{2}{3} \pi r^3$

Radius = 3.5cm

$$\text{Then volume} = \frac{2}{3} \times \frac{22}{7} \times (3.5)^3$$

$$= \frac{2}{3} \times \frac{22}{7} \times 3.5 \times 3.5 \times 3.5$$

$$= \frac{\cancel{2}}{3} \times \frac{22}{\cancel{7}} \times \frac{\cancel{35}_7}{10^2} \times \frac{\cancel{35}_7}{10^2} \times \frac{\cancel{35}_7}{10^2}$$

$$= 89.8 \text{cm}^3$$

64. A conical pit of top diameter 3.5 m is 12 m deep. What is its capacity in kiloliters

Ans. Diameter of conical Pit = 3.5m

$$\therefore \text{Radius } r = \frac{3.5}{2} \text{m} = \frac{\cancel{35}_7}{\cancel{20}_4} = \frac{7}{4} \text{m}$$

Depth h = 12m

$$\text{Capacity of Pit} = \frac{1}{3} \pi r^2 h$$

$$= \frac{1}{3} \times \frac{\cancel{22}^{11}}{\cancel{7}} \times \frac{\cancel{7}}{4} \times \frac{7}{4^2} \times \cancel{12}^3$$

$$= \frac{77}{2} \text{m}^3$$

$$= 38.5 \text{m}^3$$

$$= 38.50 \text{ kl. } [1 \text{ m}^3 = 1 \text{ kl}]$$

65. The diagonals of a cube is 30 cm, find its volume

Ans. Let side of cube be a cm

$$\text{Diagonal} = \sqrt{3}a$$

$$\sqrt{3}a = 30$$

$$a = \frac{30}{\sqrt{3}}$$

$$\text{Volume of cube} = a^3 = \left(\frac{30}{\sqrt{3}}\right)^3$$

$$= \frac{27000}{3\sqrt{3}} = \frac{9000}{\sqrt{3}} \text{ cm}^3$$

66. A cylindrical tank has a capacity of 6160 m³ find its depth if the diameter of the base is 28 m

Ans. Diameter of the base = 28m

$$\text{Radius } r = \frac{28}{2} = 14 \text{ m}$$

$$\text{Volume} = \pi r^2 h = 6160$$

$$\frac{22}{7} \times 14 \times 14 \times h = 6160$$

$$h = \frac{6160 \times 7}{22 \times 14 \times 14} = 10 \text{ m}$$

Hence depth of tank = 10m

67. Find the volume of a sphere whose surface area is 154 cm^2

Ans. Given surface area of sphere = 154 cm^2

$$4\pi r^2 = 154$$

$$r^2 = \frac{154}{4\pi} = \frac{154 \cancel{\pi^7}}{4 \times \cancel{22}^4} \times 7$$

$$= \frac{49}{4}$$

$$r = \frac{7}{2} \text{ cm}$$

$$\text{Volume of sphere} = \frac{4}{3} \pi r^3$$

$$= \frac{4}{3} \times \frac{22}{7} \times \left(\frac{7}{2}\right)^3 \text{ cm}^3$$

$$= \frac{\cancel{4}}{3} \times \frac{\cancel{22}^{11}}{\cancel{7}} \times \frac{\cancel{7}}{\cancel{2}} \times \frac{7}{\cancel{2}} \times \frac{7}{\cancel{2}}$$

$$= 179.66 \text{ cm}^3$$

68. If the volume of a right circular cone of height 9 cm is $48\pi \text{ cm}^3$ Find the diameter of its base

Ans. Given volume of cone = $48\pi \text{ cm}^3$ and height = 9cm

$$\text{Volume of cone} = \frac{1}{3} \pi r^2 h$$

$$\frac{1}{3} \pi r^2 h = 48\pi$$

$$r^2 \times 9 = 48 \times 3$$

$$r^2 = \frac{\cancel{48}^{16} \times \cancel{3}}{\cancel{9}^3}$$

$$r = 4\text{cm}$$

$$\text{Diameter} = 2r = 2 \times 4 = 8\text{cm}$$

69. The volume of a cylinder is 69300 cm^3 and its height is 50 cm. Find its curved surface area

Ans. Volume = $\pi r^2 h = 69300$ and $h = 50\text{ cm}$

$$\Rightarrow \frac{22}{7} \times r^2 \times 50 = 69300$$

$$r^2 = \frac{69300 \times 7}{22 \times 50} = 441$$

$$r = \sqrt{441} = 21\text{cm}$$

$$\therefore \text{Curved surface area} = 2\pi r h$$

$$= 2 \times \frac{22}{7} \times 21 \times 50 = 6600\text{cm}^2$$

70. The volume of a cube is 1000cm^3 , Find its total surface area.

Ans. Volume = $a^3 = 1000\text{cm}^3$

$$a = 10\text{cm}$$

$$\text{Total surface area} = 6a^2 = 6 \times 100$$

$$= 600\text{cm}^2$$

CBSE Class 9 Mathemaics
Important Questions
Chapter 13
Surface Areas and Volumes

3 Marks Quetions

1. A small indoor green house (herbarium) is made entirely of glass panes (including base) held together with tape. It is 30 cm long, 25 cm wide and 25 cm high.

(i) What is the surface area of the glass?

(ii) How much of tape is needed for all the 12 edges?

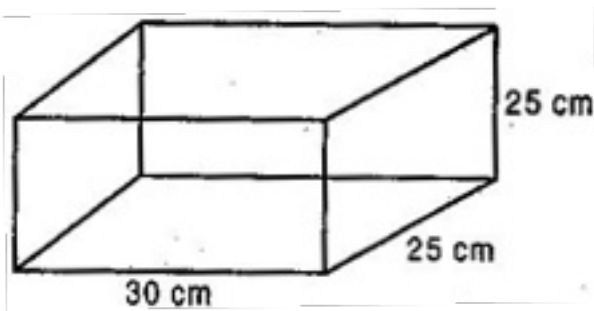

Ans. (i) Given: Length of glass herbarium (l) = 30 cm,

Breadth (b) = 25 cm and Height (h) = 25 m

Total surface area of the glass = $2(lb + bh + hl)$

$$= 2(30 \times 25 + 25 \times 25 + 25 \times 30)$$

$$= 2(750 + 625 + 750)$$

$$= 2 \times 2125 = 4250 \text{ cm}^2$$

Hence 4250 cm^2 of the glass is required to make a herbarium.

(ii) Tape is used at 12 edges.



⇒ Tape is used at 4 lengths, 4 breadths and 4 heights.

⇒ Total length of the tape = $4(l + b + h) = 2(30 + 25 + 25) = 320$ cm

Hence 320 cm of the tape is needed to fix 12 edges of herbarium.

2. A metal pipe is 77 cm long. The inner diameter of a cross section is 4 cm, the outer diameter being 4.4 cm. [See fig.]. Find its:

(i) Inner curved surface area

(ii) Outer curved surface area

(iii) Total surface area

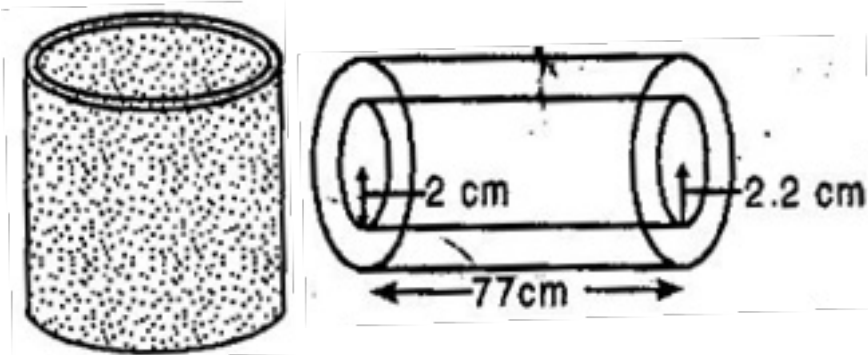

Ans. (i) Length of the pipe = 77 cm, Inner diameter of cross-section = 4 cm

⇒ Inner radius of cross-section = 2 cm

Inner curved surface area of pipe = $2\pi rh = 2 \times \frac{22}{7} \times 2 \times 77 = 2 \times 22 \times 2 \times 11 = 968$ cm²

(ii) Length of pipe = 77 cm, Outer diameter of pipe = 4.4 cm

⇒ Outer radius of the pipe = 2.2 cm

Outer surface area of the pipe = $2\pi rh = 2 \times \frac{22}{7} \times 2.2 \times 77 = 44 \times 2.2 \times 11 = 1064.8$ cm²

(iii) Now there are two circles of radii 2 cm and 2.2 cm at both the ends of the pipe.

∴ Area of two edges of the pipe = 2 (Area of outer circle – area of inner circle)

$$\begin{aligned}
&= 2(\pi R^2 - \pi r^2) = 2\pi(R^2 - r^2) \\
&= 2 \times \frac{22}{7} [(2.2)^2 - (2)^2] = \frac{44}{7}(4.84 - 4) \\
&= \frac{44}{7} \times 0.84 = 5.28 \text{ cm}^2
\end{aligned}$$

∴ Total surface area of pipe

= Inner curved surface area + Outer curved surface area + Area of two edges

$$= 968 + 1064.8 + 5.28 = 2038.08 \text{ cm}^2$$

3. Curved surface area of a cone is 308 cm^2 and its slant height is 14 cm. Find (i) radius of the base and (ii) total surface area of the cone.

Ans. (i) Slant height of cone (l) = 14 cm

Curved surface area of cone = 308 cm^2

$$\Rightarrow \pi r l = 308 \Rightarrow \frac{22}{7} \times r \times 14 = 308$$

$$\Rightarrow r = \frac{308 \times 7}{14 \times 22} \Rightarrow r = 7 \text{ cm}$$

(ii) Total surface area of the cone = Curved surface area + Area of circular base

$$= 308 + \pi r^2$$

$$= 308 + \frac{22}{7} \times (7)^2$$

$$= 462 \text{ cm}^2$$

4. A conical tent is 10 m high and the radius of its base is 24 m. Find:

(i) slant height of the tent.

(ii) cost of the canvas required to make the tent, if the cost of a m^2 canvas is Rs. 70.

Ans. Height of the conical tent (h) = 10 m

Radius of the conical tent (r) = 24 m

(i) Slant height of the tent (l) = $\sqrt{r^2 + h^2}$

$$= \sqrt{(24)^2 + (10)^2}$$

$$= \sqrt{576 + 100}$$

$$= \sqrt{676} = 26 \text{ m}$$

(ii) Canvas required to make the tent = Curved surface area of the tent

$$= \pi r l = \frac{22}{7} \times 24 \times 26 = \frac{13728}{7} m^2$$

∴ Cost of $1 m^2$ canvas = Rs. 70

$$\therefore \text{Cost of } \frac{13728}{7} m^2 \text{ canvas} = 70 \times \frac{13728}{7} = \text{Rs. } 137280$$

5. What length of tarpaulin 3 m wide will be required to make conical tent of height 8 m and base radius 6 m? Assume that the extra length of material that will be required for stitching margins and wastage in cutting is approximately 20 cm. (Use $\pi = 3.14$)

Ans. Height of the conical tent (h) = 8 m and Radius of the conical tent (r) = 6 m

Slant height of the tent (l) = $\sqrt{r^2 + h^2}$

$$= \sqrt{(6)^2 + (8)^2}$$

$$= \sqrt{36 + 64}$$

$$= \sqrt{100} = 10 \text{ m}$$

$$\text{Area of tarpaulin} = \text{Curved surface area of tent} = \pi r l = 3.14 \times 6 \times 10 = 188.4 \text{ m}^2$$

Width of tarpaulin = 3 m

Let Length of tarpaulin = L

$$\therefore \text{Area of tarpaulin} = \text{Length} \times \text{Breadth} = L \times 3 = 3L$$

Now According to question, $3L = 188.4$

$$\Rightarrow L = \frac{188.4}{3} = 62.8 \text{ m}$$

The extra length of the material required for stitching margins and cutting is 20 cm = 0.2 m.

So the total length of tarpaulin bought is $(62.8 + 0.2) \text{ m} = 63 \text{ m}$

6. A bus stop is barricaded from the remaining part of the road, by using 50 hollow cones made of recycled cardboard. Each cone has a base diameter of 40 cm and height 1 m. If the outer side of each of the cones is to be painted and the cost of painting is Rs. 12 per m^2 , what will be the cost of painting all these cones? (Use $\pi = 3.14$ and take $\sqrt{1.04} = 1.02$)

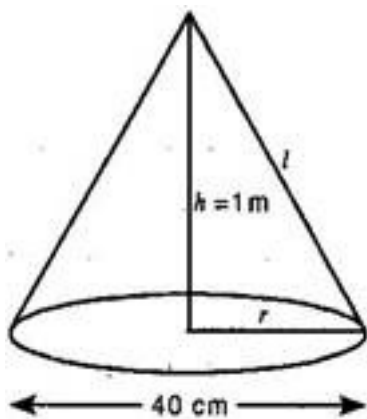

Ans. Diameter of cone = 40 cm

$$\Rightarrow \text{Radius of cone } (r) = \frac{40}{2}$$

$$= 20 \text{ cm}$$

$$= \frac{20}{100} \text{ m}$$

$$= 0.2 \text{ m}$$

$$\text{Height of cone } (h) = 1 \text{ m}$$

$$\text{Slant height of cone } (l) = \sqrt{r^2 + h^2}$$

$$= \sqrt{(0.2)^2 + (1)^2} = \sqrt{1.04} \text{ m}$$

$$\text{Curved surface area of cone} = \pi r l = 3.14 \times 0.2 \times \sqrt{1.04}$$

$$= 0.64056 \text{ m}^2$$

$$\therefore \text{Cost of painting } 1 \text{ m}^2 \text{ of a cone} = \text{Rs. } 12$$

$$\therefore \text{Cost of painting } 0.64056 \text{ m}^2 \text{ of a cone} = 12 \times 0.64056 = \text{Rs. } 7.68672$$

$$\therefore \text{Cost of painting of 50 such cones} = 50 \times 7.68672 = \text{Rs. } 384.34 \text{ (approx.)}$$

7. The radius of a spherical balloon increases from 7 cm to 14 cm as air is being pumped into it. Find the ratio of surface areas of the balloon in the two cases.

Ans. I case: Radius of balloon $(r) = 7 \text{ cm}$

$$\text{Surface area of balloon} = 4\pi r^2 = 4\pi \times 7 \times 7 \text{ cm}^2 \dots\dots\dots(i)$$

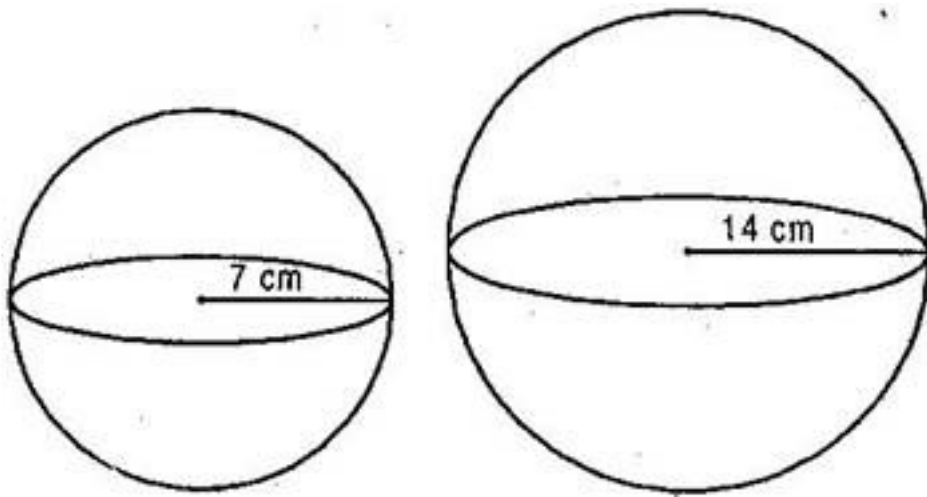

II case: Radius of balloon (R) = 14 cm

$$\text{Surface area of balloon} = 4\pi R^2 = 4\pi \times 14 \times 14 \text{ cm}^2 \dots\dots\dots(\text{ii})$$

Now, Ratio [from eq. (i) and (ii)],

$$\frac{\text{CSA in first case}}{\text{CSA in second case}} = \frac{4\pi \times 7 \times 7}{4\pi \times 14 \times 14} = \frac{1}{4}$$

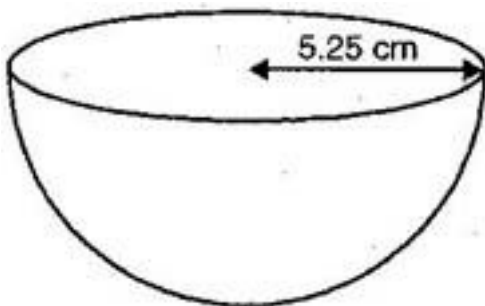

Hence, required ratio = 1: 4

8. A village having a population of 4000 requires 150 litres of water per head per day. It has a tank measuring 20 m by 15 m by 6 m. For how many days will the water of this tank last?

Ans. Capacity of cuboidal tank = $l \times b \times h = 20 \text{ m} \times 15 \text{ m} \times 6 \text{ m} = 1800 \text{ m}^3 = 1800 \times 1000 \text{ liters}$

$[\because 1000 \text{ l} = 1 \text{ m}^3]$

= 1800000 liters

Water required by her head per day = 150 liters

Water required by 4000 persons per day = $150 \times 4000 = 600000$ liters

Number of days the water will last = $\frac{\text{Capacity of tank (in liter)}}{\text{Total water required per day (in liters)}}$

$$= \frac{1800000}{600000} = 3$$

Hence water of the given tank will last for 3 days.

9. A godown measures $40 \text{ m} \times 25 \text{ m} \times 15 \text{ m}$. Find the maximum number of wooden crates each measuring $1.5 \text{ m} \times 1.25 \text{ m} \times 0.5 \text{ m}$ that can be stored in the godown.

Ans. Capacity of cuboidal godown = $40 \text{ m} \times 25 \text{ m} \times 15 \text{ m} = 15000 \text{ m}^3$

Capacity of wooden crate = $1.5 \text{ m} \times 1.25 \text{ m} \times 0.5 \text{ m} = 0.9375 \text{ m}^3$

Maximum number of crates that can be stored in the godown = $\frac{\text{Volume of godown}}{\text{Volume of one crate}}$

$$= \frac{15000}{0.9375} = 16000$$

Hence maximum 16000 crates can be stored in the godown.

10. Find the minimum number of bricks each measuring $22.5 \text{ cm} \times 11.5 \text{ cm} \times 7.5 \text{ cm}$ required to construct a wall 10 m long, 6 m high and 1.5 m thick.



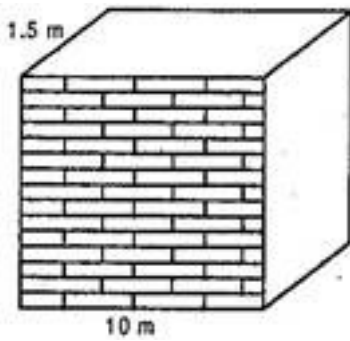

Ans. Volume of one cuboidal brick = $l \times b \times h$

$$= 22.5 \text{ cm} \times 11.5 \text{ cm} \times 7.5 \text{ cm}^3$$

$$= 1940.625 \text{ cm}^3$$

$$= 0.001940625 \text{ m}^3$$

Volume of cuboidal wall = $10 \text{ m} \times 6 \text{ m} \times 1.5 \text{ m}$

$$= 90 \text{ m}^3$$

Minimum number of bricks required = $\frac{\text{Volume of wall}}{\text{Volume of a brick}}$

$$= \frac{90}{0.001940625} = \frac{90}{\frac{1940625}{1000000000}}$$

$$= \frac{90000000000}{1940625} = 46376.81$$

$$= 46377 \text{ [Since bricks cannot be in fraction]}$$

11. The circumference of the base of a cylindrical vessel is 132 cm and its height is 25 cm. How many litres of water can it hold? ($1 \text{ m}^3 = 1000 \text{ l}$)

Ans. Height of vessel = (h) = 25 cm

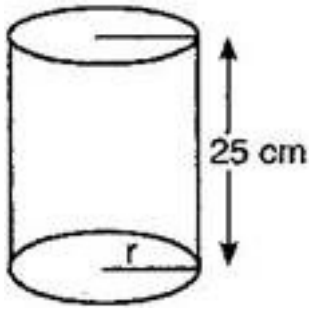

Circumference of base of vessel = 132 cm

$$\Rightarrow 2\pi r = 132 \Rightarrow 2 \times \frac{22}{7} \times r = 132$$

$$\Rightarrow r = \frac{132 \times 7}{2 \times 22} = 21 \text{ cm}$$

$$\text{Now, Volume of cylindrical vessel} = \pi r^2 h = \frac{22}{7} \times 21 \times 21 \times 35 = 34650 \text{ cm}^3$$

$$= \frac{34650}{1000} \text{ liters } [\because 1000 \text{ cm}^3 = 1 \text{ liter}]$$

$$= 34.65 \text{ liters}$$

12. The inner diameter of a cylindrical wooden pipe is 24 cm and its out diameter is 28 cm. The length of the pipe is 35 cm. Find the mass of the pipe, if 1 cm^3 of wood has a mass of 0.5 g.

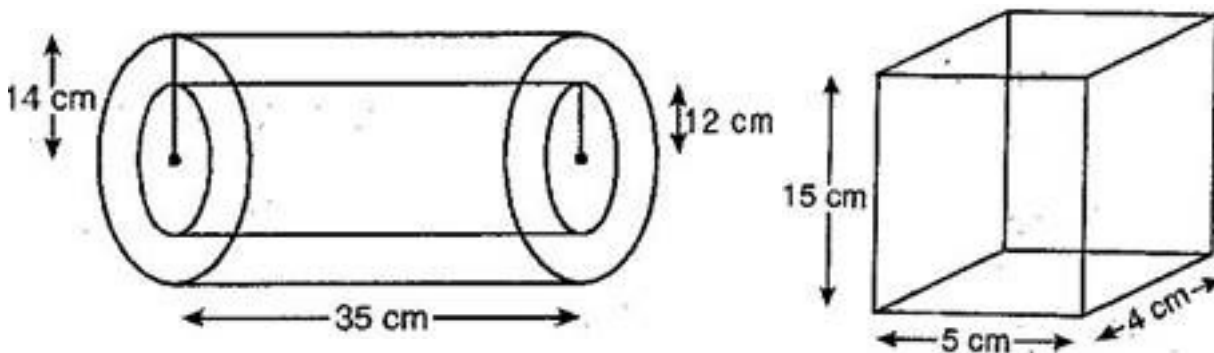

Ans. Inner diameter of pipe = 28 cm

$$\therefore \text{Inner radius of pipe } (r) = \frac{24}{2} = 12 \text{ cm}$$

And Outer diameter of pipe = 28 cm

$$\therefore \text{Outer radius of pipe } (R) = \frac{28}{2} = 14 \text{ cm}$$

Length of pipe (h) = 35 cm

Volume of wood = Volume of outer cylinder – Volume of inner cylinder

$$= \pi R^2 h - \pi r^2 h = \pi h (R^2 - r^2)$$

$$= \frac{22}{7} \times 35 [(14)^2 - (12)^2]$$

$$= 110 [196 - 144] = 110 \times 52 = 5720 \text{ cm}^3$$

$$\therefore \text{Weight of } 1 \text{ cm}^3 \text{ of wood} = 0.6 \text{ g}$$

$$\therefore \text{Weight of } 5720 \text{ cm}^3 \text{ of wood} = 0.6 \times 5720$$

$$= 3432 \text{ g} = 3.432 \text{ kg}$$

13. A soft drink is available in two packs (i) a tin can with a rectangular base of length 5 cm and width 4 cm, having height of 15 cm (ii) a plastic cylinder with circular base of diameter 7 cm and height 10 cm. Which container has greater capacity and how much?

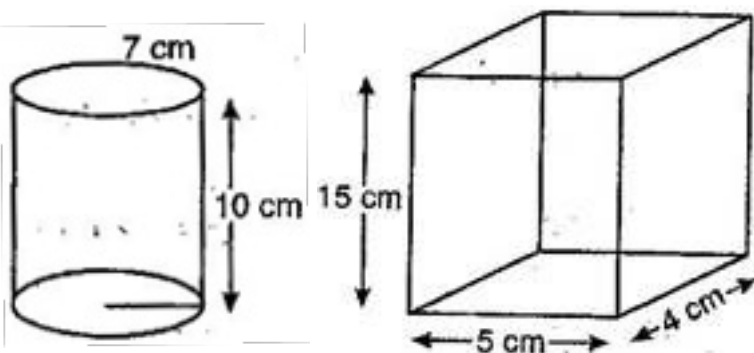

Ans. I case: Length of tin (l) = 5 cm, Width of tin (b) = 4 cm

and Height of tin (h) = 15 cm

Then, Capacity of tin = $l \times b \times h = 5 \times 4 \times 15 = 300 \text{ cm}^3$

II case: Diameter of base of cylinder = 7 cm

\therefore Radius of base of cylinder (r) = $\frac{7}{2}$ cm

Height of cylinder (h') = 10 cm

Capacity of cylinder = $\pi r^2 h' = \frac{22}{7} \times \frac{7}{2} \times \frac{7}{2} \times 10 = 385 \text{ cm}^3$

From the cases I and II, we observed that cylindrical container has greater capacity by $(385 - 300) = 85 \text{ cm}^3$.

14. It costs Rs. 2200 to paint the inner curved surface of a cylindrical vessel 10 m deep. If the cost of painting is at the rate of Rs. 20 per m^2 , find:

(i) inner curved surface area of the vessel.

(ii) radius of the base.

(iii) capacity of the vessel.

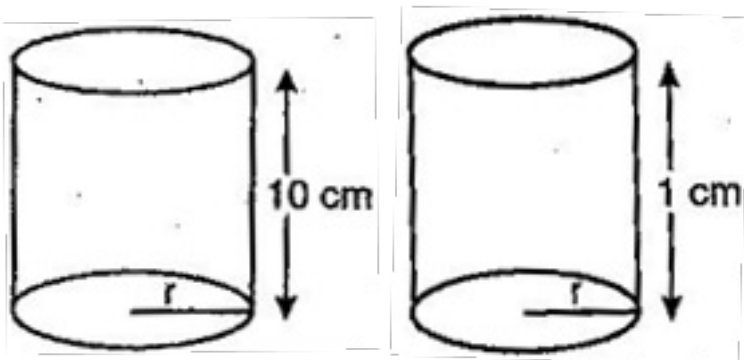

Ans. Total cost to paint inner curved surface area of the vessel = Rs. 2200

Rate = Rs. 20 per square meter

$$(i) \text{ Inner curved surface area of vessel} = \frac{\text{Total cost}}{\text{Rate}} = \frac{2200}{20} = 110 \text{ m}^2$$

$$(ii) \text{ Depth of the vessel } (h) = 10 \text{ m}$$

Now, Inner surface area of vessel = 110 m^2

$$\Rightarrow 2\pi rh = 110$$

$$\Rightarrow 2 \times \frac{22}{7} \times r \times 10 = 110$$

$$\Rightarrow r = \frac{110 \times 7}{2 \times 22 \times 10} = 1.75 \text{ m}$$

(iii) Since $r = 1.75 \text{ m}$ and $h = 10 \text{ m}$

$$\therefore \text{Capacity of vessel} = \text{Volume of cylinder} = \pi r^2 h$$

$$= \frac{22}{7} \times 1.75 \times 1.75 \times 10 = 96.25 \text{ m}^3$$

$$= 96.25 \text{ kl} [\because 1 \text{ m}^3 = 1 \text{ kl}]$$

15. The capacity of a closed cylindrical vessel of height 1 m is 15.4 litres. How many square meters of metal sheet would be needed to make it?

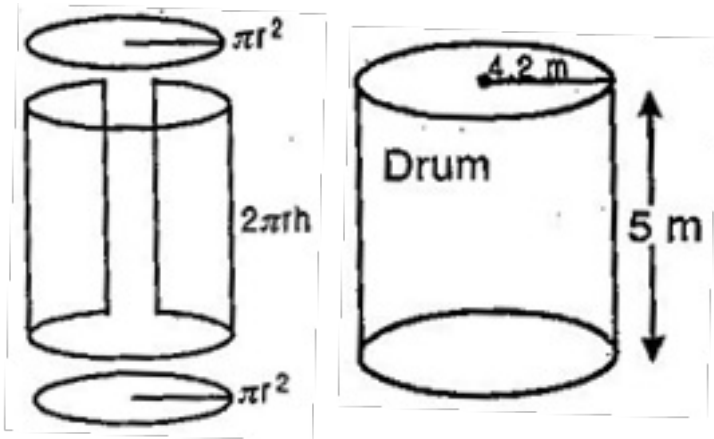

Ans. Height of the vessel (h) = 1 m

Capacity of vessel = 15.4 liters

$$= \frac{15.4}{1000} \text{ kilo liters}$$

$$= 0.0154 \text{ m}^3 [\because 1 \text{ m}^3 = 1 \text{ kl}]$$

$$\Rightarrow \pi r^2 h = 0.0154$$

$$\Rightarrow \frac{22}{7} \times r^2 \times 1 = 0.0154$$

$$\Rightarrow r^2 = \frac{0.0154 \times 7}{22}$$

$$\Rightarrow r^2 = 0.0007 \times 7 = 0.0048$$

$$\Rightarrow r = 0.07 \text{ m}$$

Now, Area of metal sheet required = TSA of cylindrical vessel

$$= 2\pi r(r + h)$$

$$= 2 \times \frac{22}{7} \times 0.07(1 + 0.07)$$

$$= \frac{44}{7} \times 0.07 \times 1.07$$

$$= 0.4708 \text{ m}^2$$

16. Find the capacity of a conical vessel with:

(i) Radius 7 cm, Slant height 25 cm

(ii) Height 12 cm, Slant height 13 cm

Ans. (i) Given: $r = 7 \text{ cm}$, $l = 25 \text{ cm}$

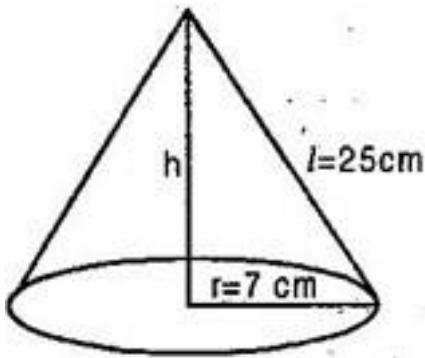

$$h = \sqrt{l^2 - r^2}$$

$$= \sqrt{(25)^2 - (7)^2}$$

$$= \sqrt{625 - 49}$$

$$= \sqrt{576} = 24 \text{ cm}$$

$$\text{Capacity of conical vessel} = \frac{1}{3} \pi r^2 h$$

$$= \frac{1}{3} \times \frac{22}{7} \times 7 \times 7 \times 24 = 1232 \text{ cm}^3$$

$$= 1.232 \text{ liters } [\because 1000 \text{ cm}^3 = 1 \text{ liter}]$$

(ii) Given: $h = 12 \text{ cm}$, $l = 13 \text{ cm}$

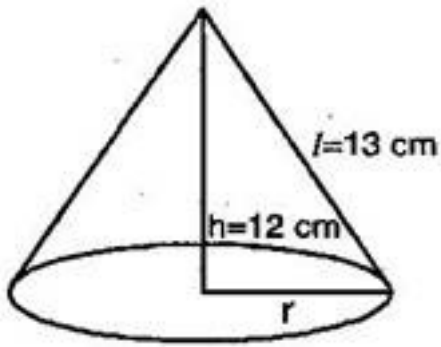

$$r = \sqrt{l^2 - h^2} = \sqrt{(13)^2 - (12)^2} = \sqrt{169 - 144}$$

$$= \sqrt{25} = 5 \text{ cm}$$

$$\text{Capacity of conical vessel} = \frac{1}{3} \pi r^2 h$$

$$= \frac{1}{3} \times \frac{22}{7} \times 5 \times 5 \times 12 = \frac{2200}{7} \text{ cm}^3$$

$$= \frac{2200}{7} \times \frac{1}{1000} \text{ liters } [\because 1000 \text{ cm}^3 = 1 \text{ liter}]$$

$$= \frac{11}{35} \text{ liter}$$

17. If the triangle ABC in question 7 above is revolved about the side 5 cm, then find the volume of the solid so obtained. Find, also, the ratio of the volume of the two solids obtained.

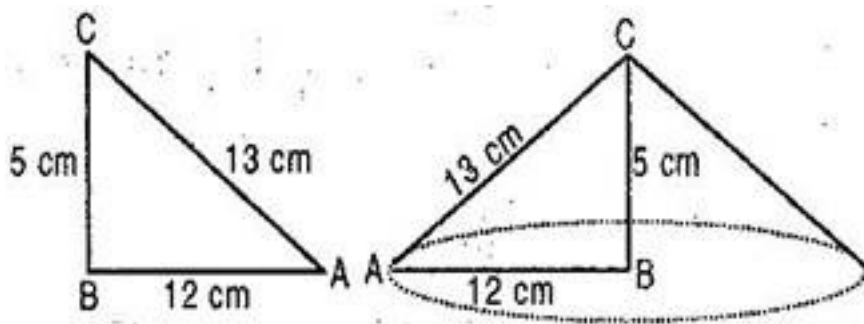

Ans. When right angled triangle ABC is revolved about side 5 cm, then the solid formed is a cone.

In that cone, Height (h) = 5 cm

And radius (r) = 12 cm

Therefore, Volume of cone = $\frac{1}{3} \pi r^2 h$

$$= \frac{1}{3} \pi \times 12 \times 12 \times 5$$

$$= 240\pi \text{ cm}^3$$

$$\text{Now, } \frac{\text{Volume of cone in Q. No. 7}}{\text{Volume of cone in Q. No. 8}} = \frac{100\pi}{240\pi} = \frac{5}{12}$$

∴ Required ratio = 5: 12

18. The diameter of the moon is approximately one-fourth the diameter of the earth. What fraction is the volume of the moon of the volume of the earth?

Ans. Let diameter of earth be x

$$\therefore \text{Radius of earth } (r) = \frac{x}{2}$$

Now, Volume of earth = $\frac{4}{3} \pi r^3$ [∵ Earth is considered to be a sphere]

$$= \frac{4}{3} \times \pi \times \frac{x}{2} \times \frac{x}{2} \times \frac{x}{2} = \frac{1}{8} \times \frac{4}{3} \pi x^3 \dots\dots\dots(i)$$

According to question, Diameter of moon = $\frac{1}{4} \times$ Diameter of earth = $\frac{1}{4} \times x = \frac{x}{4}$

$$\therefore \text{Radius of moon } (R) = \frac{x}{8}$$

Now, Volume of Moon = $\frac{4}{3} \pi R^3$ [\because Moon is considered to be a sphere]

$$= \frac{4}{3} \times \pi \times \frac{x}{8} \times \frac{x}{8} \times \frac{x}{8} = \frac{1}{512} \times \frac{4}{3} \pi x^3$$

$$= \frac{1}{64} \times \left[\frac{1}{8} \times \frac{4}{3} \pi x^3 \right] = \frac{1}{64} \times \text{Volume of Earth [From eq. (i)]}$$

\therefore Volume of moon is $\frac{1}{64}$ th the volume of earth.

19. How many litres of milk can a hemispherical bowl of diameter 10.5 hold?

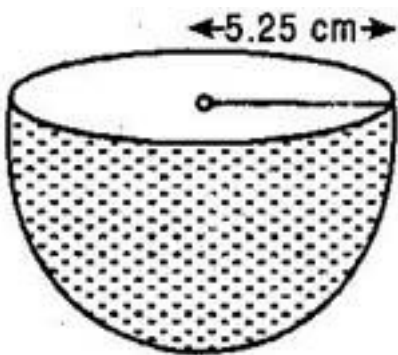

Ans. Diameter of hemispherical bowl = 10.5 cm

\therefore Radius of hemispherical bowl (r) = $\frac{10.5}{2} = 5.25$ cm

Volume of milk in hemispherical bowl = $\frac{2}{3} \pi r^3$

$$= \frac{2}{3} \times \frac{22}{7} \times 5.25 \times 5.25 \times 5.25$$

$$= \frac{2}{3} \times \frac{22}{7} \times \frac{525}{100} \times \frac{525}{100} \times \frac{525}{100} = 11 \times \frac{21}{4} \times \frac{21}{4} = 303.187 \text{ cm}^3$$

$$= \frac{303.187}{1000} \text{ liters } [\because 1000 \text{ cm}^3 = 1 \text{ l}]$$

= 0.303187 liters = 0.303 liters (approx.)

20. Find the volume of a sphere whose surface area is 154 cm^2 .

Ans. Surface area of sphere = 154 cm^2

$$\Rightarrow 4\pi r^2 = 154 \Rightarrow 4 \times \frac{22}{7} \times r^2 = 154$$

$$\Rightarrow r^2 = \frac{154 \times 7}{4 \times 22} = \frac{49}{4} \Rightarrow r = \frac{7}{2} \text{ cm}$$

$$\text{Now, Volume of sphere} = \frac{4}{3}\pi r^3 = \frac{4}{3} \times \frac{22}{7} \times \frac{7}{2} \times \frac{7}{2} \times \frac{7}{2}$$

$$= \frac{1}{3} \times 11 \times 49 = \frac{539}{3} = 179\frac{2}{3} \text{ cm}^3$$

21. A wooden bookshelf has external dimensions as follows: Height = 110 cm, Depth = 25 cm, Breadth = 85 cm [See fig.]. The thickness of the planks is 5 cm everywhere. The external faces are to be polished and the inner faces are to be painted. If the rate of polishing is 20 paise per cm^2 and the rate of painting is 10 paise per cm^2 , find the total expenses required for polishing and painting the surface of the bookshelf

Ans. External faces to be polished

= Area of six faces of cuboidal bookshelf – 3 (Area of open portion ABCD)

$$= 2(110 \times 25 + 25 \times 85 + 85 \times 110) - 3(75 \times 30)$$

$$[\because AB = 85 - 5 - 5 = 75 \text{ cm and AD} = \frac{1}{3} \times 110 - 5 - 5 - 5 - 5 = 30 \text{ cm}]$$

$$= 2(2750 + 2125 + 9350) - 3 \times 2250$$

$$= 2 \times 14225 - 6750$$

$$= 28450 - 6750$$



$$= 21700 \text{ cm}^2$$

Now, cost of painting outer faces of wooden bookshelf at the rate of 20 paise.

$$= \text{Rs. } 0.20 \text{ per cm}^2 = \text{Rs. } 0.20 \times 21700 = \text{Rs. } 4340$$

Here, three equal five sides inner faces.

Therefore, total surface area = $3[2(30+75)20 + 30 \times 75]$ [\because Depth = $25 - 5 = 20$ cm]

$$= 3[2 \times 105 \times 20 + 2250] = 3[4200 + 2250]$$

$$= 3 \times 6450 = 19350 \text{ cm}^2$$

Now, cost of painting inner faces at the rate of 10 paise i.e. Rs. 0.10 per cm^2 .

$$= \text{Rs. } 0.10 \times 19350 = \text{Rs. } 1935$$

22. If diameter of a sphere is decreased by 25% then what percent does its curved surface area decrease?

Ans. Diameter of original sphere = $D = 2R \Rightarrow R = \frac{D}{2}$

$$\text{Curved surface area of original sphere} = 4\pi R^2 = 4\pi \left(\frac{D}{2}\right)^2 = \pi D^2$$

$$\text{According to the question, Decreased diameter} = 25\% \text{ of } D = \frac{25}{100} D = \frac{D}{4}$$

$$\therefore \text{Diameter of new sphere} = D - \frac{D}{4} = \frac{3D}{4}$$

$$\therefore \text{Radius of new sphere} = \frac{3D}{8}$$

$$\text{Now, curved surface area of new sphere} = 4\pi r^2 = 4\pi \left(\frac{3D}{8}\right)^2 = \frac{9\pi}{16} D^2$$

$$\text{Change in curved surface area} = \pi D^2 - \frac{9\pi}{16} D^2$$

$$= \frac{7}{16} \pi D^2$$

$$\text{Percent change in the curved surface area} = \frac{\text{Change in curved surface area}}{\text{Curved surface area of original sphere}} \times 100$$

$$= \frac{\frac{7}{16} \pi D^2}{\pi D^2} \times 100 = \frac{7}{16} \times 100 = 43.75\%$$

23. The surface area of cuboids is 3328 m^2 ; its dimensions are in the ratio 4:3:2. Find the volume of the cuboid.

Ans. Let the dimensions of the cuboid be $4x$, $3x$ and $2x$ meters

$$\text{Surface area of the cuboid} = 2(4x \times 3x + 3x \times 2x + 2x \times 4x) \text{ sq m}$$

$$= 2(12x^2 + 6x^2 + 8x^2) \text{ sq m}$$

$$= 52x^2 \text{ sq m} \rightarrow (i)$$

$$\text{Given surface area} = 3328 \text{ sq m}$$

From (i) and (ii) we get

$$52x^2 = 3328$$

$$\text{or } x^2 = \frac{3328}{52} = 64$$

$$\text{or } x = 8$$

$$\therefore 4x = 32, 3x = 24 \text{ and } 2x = 16$$

Thus the dimensions of the cuboid are 32m, 24m and 16m

$$\therefore \text{Volume of the cuboid} = (32 \times 24 \times 16) m^3$$

$$= 12288 \text{cu m}$$

24. The volume of a rectangular slower of stone is 10368 dm^3 and its dimensions are in the ratio of 3:2:1. (i) Find the dimensions (ii) Find the cost of polishing its entire surface @ Rs. 2 per dm^2 .

Ans. Let the length of the block be $3x \text{ dm}$

Width = $2 \times \text{dm}$ and height = $x \text{ dm}$

$$\text{Volume of the block} = 10368 \text{ dm}^3$$

$$\therefore 3x \times 2x \times x = 10368$$

$$\text{or } x^3 = \frac{10368}{6}$$

$$= 1728$$

$$\therefore x = \sqrt[3]{1728}$$

$$= \sqrt[3]{12 \times 12 \times 12}$$

$$= 12$$

$$\text{also } 2x = 24 \text{ and } 3x = 36$$

Thus dimensions of the block are 36dm, 24dm and 12dm

$$\text{Surface area of the block} = 2(36 \times 24 + 24 \times 12 + 36 \times 12) \text{ dm}^2$$

$$= 2(864 + 288 + 432) \text{ dm}^2$$

$$= 2 \times 1584 \text{ dm}^2$$

$$= 3168 \text{ dm}^2$$

$$\text{Cost of polishing the surface} = \text{Rs}(2 \times 3168)$$

$$= \text{Rs. } 6336$$

25. In a cylindrical drum of radius 4.2 m and height 3.5 m, how many full bags of wheat can be emptied if the space required for each bag is 2.1 cu m.

$$\text{Ans. Radius of the drum} = 4.2 \text{ m} = \frac{42}{10} \text{ m}$$

$$\text{Height of the drum} = 3.5 \text{ m} = \frac{35}{10} \text{ m}$$

$$\therefore \text{Volume of the drum} = \pi r^2 h \text{ cu units}$$

$$= \left(\frac{22}{7} \times \frac{42}{10} \times \frac{42}{10} \times \frac{35}{10} \right) \text{ cu m} \dots (i)$$

$$\text{Volume of wheat in each bags} = 2.1 \text{ cu m} = \frac{21}{10} \text{ cu m} \rightarrow (ii)$$

$$\therefore \text{No. of bags} = \frac{\text{volume of drum}}{\text{volume of wheat in each bag}}$$

$$= \frac{\frac{22}{7} \times \frac{42}{10} \times \frac{42}{10} \times \frac{35}{10}}{\frac{21}{10}}$$

$$= \frac{924}{10} = 92.4$$

$$= 92$$



Hence the number of full bags is 92

26. The inner diameter of a cylindrical wooden tripe is 24 cm. and its outer diameter is 28 cm. the length of wooden tripe is 35 cm. find the mass of the tripe, if 1 cu cm of wood has a mass of 0.6 g.

Ans. Inside diameter of the pipe = 24cm

Outside diameter of the pipe = 28cm

Length of the pipe = 35cm = (h says)

Outside radius of the pipe = $\frac{28}{2} \text{ cm} = 14 \text{ cm} = R(\text{says})$

Volume of the wood = External volume – Internal volume

$$= \pi r^2 h - \pi^2 l$$

$$= \pi \times 35 (14^2 - 12^2) \text{ cu cm}$$

$$= \frac{22}{7} \times 35 (14 + 12) (14 - 12) \text{ cu cm}$$

$$= 5720 \text{ cu cm}$$

Mass of 1cu cm = 0.6g

$$\therefore \text{Mass of the pipe} = (0.6 \times 5720) \text{ g}$$

$$= 3432 \text{ g}$$

$$= 3.432 \text{ kg}$$

27. A patient in a hospital is given soup daily in a cylindrical bowl of a diameter 7cm. If the bowl is filled with soup to height of 4cm. How much soup the hospital has to prepare daily to serve 250 patients?

Ans. Diameter of the bowl = 7 cm.

$$\text{Radius of the bowl} = \frac{7}{2} \text{ cm}$$

Height up to which soup is filled (h) = 4 cm.

$$\text{Volume of the soup in one bowl} = \pi r^2 h$$

$$= \frac{22}{7} \times \frac{7}{2} \times \frac{7}{2} \times 4 \text{ cu cm.}$$

$$= 154 \text{ cu cm}$$

\therefore soup given to one patient = 154 cu cm.

$$\text{Soup given to 250 patients} = 250 \times 154 \text{ cu cm.}$$

$$= 38500 \text{ cu cm.}$$

$$= \frac{38500}{1000} \text{ ltrs } \because [\text{ltrs} = 1000 \text{ cu cm}]$$

$$= 38.5 \text{ ltrs.}$$

Hence the hospital has to prepare 38.5 litre daily to serve 250 patients.

28. The diameter of a roller is 84cm and its length is 120cm. It takes 500 complete revolutions to move once over to level a playground.

(a) Find the area of playground in sq m.

(b) Determine the cost of leveling the playground at the rate of Rs 1.75 per sq m.

$$\text{Ans. (a) } R = \text{Radius of the roller} = \frac{84}{2} \text{ Area} = 42 \text{ cm. as } - 0.42 \text{ m.}$$

$$H = \text{length of the roller} = 120 \text{ cm.} = 1.2 \text{ m.}$$



Area covered in the revolution = $2\pi rh$ sq unit

$$= \frac{2 \times 22 \times 0.42 \times 1.2}{7}$$

$$= 3.168 \text{ sq m.}$$

∴ Area covered in 500 revolutions = 500×3.168 sq m.

$$= 1584 \text{ sq m.}$$

thus area of playground = 1584 sq m.

(b) cost of leveling 1 sq m. of playground = Rs 1.75

Cost of total leveling = Rs (1584×1.75)

$$= \text{Rs } 2772$$

29. A metal cube of edge 12 cm is melted and formed into three similar cubes. If the edge of two smaller cubes is 6cm and 8cm, find the edge of the third smaller cube (Assuming that there is no loss of metal during melting).

Ans. Volume of cube with edge 12cm = $(12)^3$ cu cm.

$$= 1728 \text{ cu cm.(i)}$$

Volume of the first smaller cube with edge 6cm = $(6)^3$ cu cm.

$$= 216 \text{ cu cm.(ii)}$$

Volume of the second smaller cube with edge 8cm. = $(8)^3$ cu cm.

$$= 512 \text{ cu cm.(iii)}$$

Let the edge of the third smaller cube be a cm.

∴ Volume of the third smaller cube = a^3 cm³ → (iv)

$$216 + 512 + a^3 = 1728 \text{ [using (i) and (ii)]}$$

By the given condition.

$$\text{area } 728 a^3 = 1728$$

$$\text{Area } a^3 = 1728 - 728 = 1000 = (10)^3$$

$$\therefore a = 10$$

Thus the edge of the third required cube is 10 cm.

30. How many bricks, each measuring 18cm by 12cm by 10cm will be required to build a wall 15m long 6dm wide and 6.5m high when $\frac{1}{10}$ of its volumes occupied by mastar?

Please find the cost of the bricks to the nearest rupees, at Rs 1100 per 1000 bricks.

Ans. Length of the wall = 15 m. = 1500 cm.

Width of the wall = 6 dm. = 60 cm.

Height of the wall = 6.5 m. = 650 cm.

$$\therefore \text{Volume of the wall} = (1500 \times 60 \times 650) \text{ cu cm.}$$

$$= 58500000 \text{ cu cm.} \rightarrow \text{(i)}$$

$$\text{Volume occupied by mastar} = \left(\frac{1}{10} \times 58500000 \right) \text{ cu cm.}$$

$$= 5850000 \text{ cu cm.} \rightarrow \text{(ii)}$$

$$\therefore \text{Volume occupied by bricks} = \text{(i)} - \text{(ii)}$$

$$= (58500000 - 5850000) \text{ cu cm.}$$

$$= 52650000 \text{ cu cm.} \rightarrow \text{(iii)}$$

$$\text{Volume of a brick} = (18 \times 12 \times 10) \text{ cu cm.}$$

$$= 2160 \text{ cu cm.} \rightarrow \text{(iv)}$$



∴ No of brick required = (iii) ÷ (iv)

$$= \frac{52650000}{2160}$$

$$= 24375$$

cost of 1000 bricks = Rs 1100

$$\text{Total cost} = \text{Rs } \frac{24375 \times 1100}{1000}$$

$$= \text{Rs } 26812.50$$

$$= \text{Rs } 26813.$$

31. A river 3 m deep and 40 m wide is flowing at the rate of 2 km per hour. How much will fall into the sea in a minute?

Ans. Depth of river = 3m

Water of the river = 40m

Rate of flow of water = 2km/hr = 2000m/hr

∴ Volume of water flowing in one hour

$$= 2000 \times 40 \times 3$$

$$= 240000m^3$$

$$\text{Hence Volume of water flowing in one minute} = \frac{240000}{60} = 4000m^3$$

32. If the lateral surface of a cylinder is 94.2 cm^2 and its height is 5 cm. then find

(i) radius of its base (ii) its volume [$\pi = 3.14$]

Ans. Given lateral surface of cylinder = 94.2 cm^2

$$2\pi rh = 94.2\text{cm}^2$$

$$H = 5\text{cm}$$

$$2\pi r \times 5 = 94.2$$

$$r = \frac{94.2}{10\pi} = \frac{94.2}{10 \times 3.14} \text{cm}$$

$$R = 3\text{cm}$$

$$\text{(ii) Volume of cylinder} = \pi r^2 h$$

$$= 3.14 \times 3^2 \times 5$$

$$= 141.3\text{cm}^3$$

33. A shot put is a metallic sphere of radius 4.9 cm If the density of the metal is 7.8 g per cm^3 Find the mass of the shot put.

$$\text{Ans. Volume of sphere} = \frac{4}{3} \pi r^3 \text{ and radius } r = 4.9 \text{ cm}$$

$$= \frac{4}{3} \times \frac{22}{7} \times 4.9 \times 4.9 \times 4.9 \text{cm}^3$$

$$= 493\text{cm}^3$$

Mass of 1cm^3 of metal is 7.8g

Mass of the shot put = volume \times density

$$= 7.8 \times 493 \text{g}$$

$$= 3845.44\text{g} = 3.85\text{kg}$$

34. The capacity of a hemispherical tank is 155.232 l . Find its radius.



Ans. Capacity of tank = Its Volume = $\frac{2}{3} \pi r^3$

$$\frac{2}{3} \pi r^3 = 155.232l$$

$$= 155.232 \times 1000 \text{ cm}^3$$

$$= 155232 \text{ cm}^3$$

$$\frac{2}{3} \times \frac{22}{7} \times r^3 = 155232$$

$$r^3 = \frac{155232 \times 3 \times 7}{2 \times 22}$$

$$r^3 = 3528 \times 3 \times 7$$

$$r^3 = (2 \times 3 \times 7)^3$$

$$r = 2 \times 3 \times 7 = 42 \text{ cm}$$

Hence radius of tank = 42cm

35. What length of tarpaulin 3 m wide will required to make conical tent of height 8 m and base radius 6 m? Assume that the extra length of material that will be required for stitching margins and wastage in cutting is approximately 20 cm [$\pi = 3.14$]

Ans. Here $h=8\text{m}$ and $r=6\text{m}$

$$l = \sqrt{r^2 + h^2} = \sqrt{36 + 64} = 10 \text{ m}$$

$$\text{Curved surface area} = \pi r l$$

$$= 3.14 \times 6 \times 10 = 188.4 \text{ m}^2$$

$$\text{Length of tarpaulin required} = \frac{\text{area}}{\text{width}} = \frac{188.4}{3}$$



$$= 62.8m$$

Extra length required for wastage = 20cm=0.2m

Hence, total length required = 62.8+0.2

$$= 63m$$

36. A capsule of medicine is in the shape of a sphere of diameter 3.5 mm How much medicine (in mm^3) is needed to fill this capsule?

Ans. Given radius of capsule = $\frac{3.5}{2} mm$

Amount of medicine = Volume of capsule = $\frac{4}{3} \pi r^3$

$$= \frac{4}{3} \times \frac{22}{7} \times \frac{(3.5)^3}{2} mm^3$$

$$= \frac{4}{3} \times \frac{22}{7} \times \frac{3.5}{2} \times \frac{3.5}{2} \times \frac{3.5}{2}$$

$$= 22.46 mm^3 \text{ (approx)}$$

37. A wall of length 10 m was to be built across an open ground. The height of wall is 4 m and thickness of the wall is 34 cm. If this wall is to be built up with bricks whose dimensions are $24cm \times 12cm \times 8cm$. How many bricks would be required

Ans. Length of wall = 10m = 1000cm

Thickness = 24cm

Height = 4m = 400cm

Volume of wall = length \times thickness \times height = $1000 \times 24 \times 400 cm^3$

Now each brick is a cuboid with length = 24cm

Breadth = 12cm and height = 8cm

Volume of each brick = $l \times b \times h = 24 \times 12 \times 8 \text{ cm}^3$

Number of bricks required = $\frac{\text{volume of the wall}}{\text{volume of each brick}}$

$$= \frac{1000 \times 24 \times 400}{24 \times 12 \times 8} = 4166.6$$

The wall requires 4167 bricks.

38. The pillars of a temple are cylindrically shaped if each pillar has a circular base of radius 20cm and height 10 m. How much concrete mixture would be required to build 14 such pillars?

Ans. Radius of base of cylinder = 20cm

Height of pillar = 10m = 1000cm

Volume of each cylinder = $\pi r^2 h$

$$= \frac{22}{7} \times 20 \times 20 \times 1000 \text{ cm}^3$$

$$= \frac{8800000}{7} \text{ cm}^3$$

$$= \frac{8.8}{7} \text{ m}^3 \left[\because 1000000 \text{ cm}^3 = 1 \text{ m}^3 \right]$$

\therefore Volume of 14 pillars = volume of each cylinder $\times 14$

$$= \frac{8.8}{7} \times 14 \text{ m}^3 = 17.6 \text{ m}^3$$

So 14 pillars would need 17.6 m^3 of concrete mixture.

39. A right triangle ABC with sides 5 cm, 12cm, and 13 cm is revolved about the side 12 cm, find the volume of the solid so obtained

Ans. The solid obtained by revolving the given right triangle is a right circular cone with radius = 5cm.

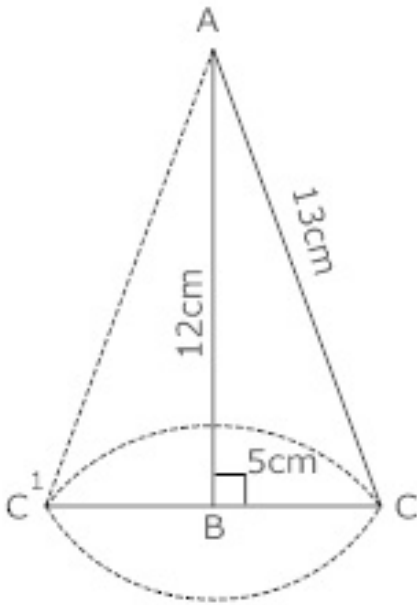

And height = 12cm

$$\therefore \text{Volume of solid} = \frac{1}{3} \pi r^2 h$$

$$= \frac{1}{3} \pi \times 5^2 \times 12 = 100\pi \text{ cm}^3$$

40. The inner diameter of a circular well is 3.5 m. It is 10 m deep find.

(i) Its inner curved surface area.

(ii) the cost of plastering this curved surface at the rate of Rs 40 per

Ans. Given Inner diameter of well = 3.5m

$$\therefore \text{Inner radius} = \frac{3.5}{2} = \frac{7}{4} \text{ m}$$

$$r = \frac{7}{4} m \text{ and depth } h = 10m$$

(i) \therefore Inner surface area = $2\pi rh$

$$= 2 \times \frac{22}{7} \times \frac{7}{4} \times 10 = 110m^2$$

(ii) The cost of plastering is Rs 40 per m^2

$$\therefore \text{Cost of plastering this surface area} = \text{Rs } 40 \times 110$$

$$= \text{Rs } 4400$$

41. A Godown measures $40m \times 25m \times 10m$. Find the maximum number of wooden crates each measuring $10m \times 1.25m \times 0.5m$ that can be stored in the go down

Ans. Dimensions of Go down

$$= 40m \times 25m \times 10m$$

$$\text{Volume of Go down} = 40m \times 25m \times 10m = 10000m^3$$

$$\text{volume of wooden carts} = 10m \times 1.25m \times 0.5m = 6.25m^3$$

$$\text{No. of wooden crates} = \frac{10,000}{6.25}$$

$$= \frac{\cancel{10,000}^{40} \times \cancel{100}^{20}}{\cancel{625}^{125}} = 800$$

Hence, 800 wooden crates are required.

42. The volume of a right circular cylinder is $576\pi \text{ cm}^3$ and radius of its base is 8 cm. Find the total surface area of the cylinder.

Ans. Volume of cylinder = $576\pi \text{ cm}^3$



$$r = 8\text{cm}$$

$$\text{Volume of cylinder} = \pi r^2 h$$

$$\cancel{\pi} r^2 h = 576 \cancel{\pi}$$

$$h = \frac{576}{r^2} = \frac{576}{8^2} = 9$$

$$H=9\text{cm}$$

$$\therefore \text{Total surface area} = 2\pi r(r+h)$$

$$= 2 \times \frac{22}{7} \times (8+9) \text{cm}^2$$

$$= \frac{16 \times 22 \times 17}{7} \text{cm}^2$$

$$= 854.989 \text{ cm}^2$$



CBSE Class 9 Mathemaics
Important Questions
Chapter 13
Surface Areas and Volumes

4 Marks Quetions

1. Shanti Sweets Stall was placing an order for making cardboard boxes for packing their sweets. Two sizes of boxes were required. The bigger of dimensions 25 cm by 20 cm by 5 cm and the smaller of dimensions 15 cm by 12 cm by 5 cm. 5% of the total surface area is required extra, for all the overlaps. If the cost of the card board is Rs. 4 for 1000 cm^2 , find the cost of cardboard required for supplying 250 boxes of each kind.

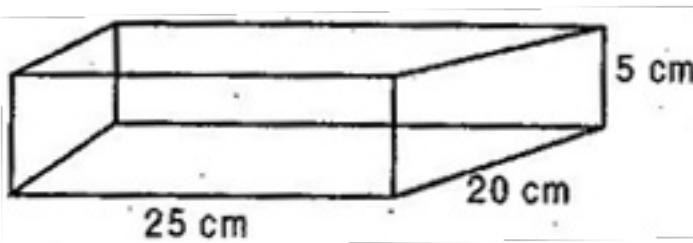

Ans. Given: Length of bigger cardboard box (L) = 25 cm

Breadth (B) = 20 cm and Height (H) = 5 cm

Total surface area of bigger cardboard box

$$= 2 (LB + BH + HL)$$

$$= 2(25 \times 20 + 20 \times 5 + 5 \times 25)$$

$$= 2(500 + 100 + 125)$$

$$= 1450 \text{ cm}^2$$

5% extra surface of total surface area is required for all the overlaps.

$$\Rightarrow 5\% \text{ of } 1450 = \frac{5}{100} \times 1450 = 72.5 \text{ cm}^2$$



Now, total surface area of bigger cardboard box with extra overlaps

$$= 1450 + 72.5 = 1522.5 \text{ cm}^2$$

⇒ Total surface area with extra overlaps of 250 such boxes

$$= 250 \times 1522.5 = 380625 \text{ cm}^2$$

Since, Cost of the cardboard for $1000 \text{ cm}^2 = \text{Rs. } 4$

$$\therefore \text{Cost of the cardboard for } 1 \text{ cm}^2 = \text{Rs. } \frac{4}{1000}$$

$$\therefore \text{Cost of the cardboard for } 380625 \text{ cm}^2 = \text{Rs. } \frac{4}{1000} \times 380625 = \text{Rs. } 1522.50$$

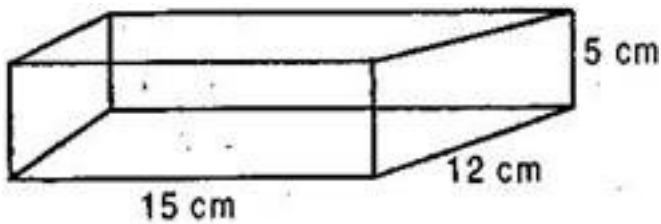

Now length of the smaller box (l) = 15 cm,

Breadth (b) = 12 cm and Height (h) = 5 cm

Total surface area of the smaller cardboard box

$$= 2(lb + bh + hl)$$

$$= 2(15 \times 12 + 12 \times 5 + 5 \times 15)$$

$$= 2(180 + 60 + 75)$$

$$= 2 \times 315 = 630 \text{ cm}^2$$

5% of extra surface of total surface area is required for all the overlaps.

$$\therefore 5\% \text{ of } 630 = \frac{5}{100} \times 630 = 31.5 \text{ cm}^2$$

$$\text{Total surface area with extra overlaps} = 630 + 31.5 = 661.5 \text{ cm}^2$$

Now Total surface area with extra overlaps of 250 such smaller boxes

$$= 661.5 \times 250 = 165375 \text{ cm}^2$$

Cost of the cardboard for $1000 \text{ cm}^2 = \text{Rs. } 4$

Cost of the cardboard for $1 \text{ cm}^2 = \text{Rs. } \frac{4}{1000}$

Cost of the cardboard for $165375 \text{ cm}^2 = \text{Rs. } \frac{4}{1000} \times 165375 = \text{Rs. } 661.50$

\therefore Total cost of the cardboard required for supplying 250 boxes of each kind

= Total cost of bigger boxes + Total cost of smaller boxes

= Rs. 1522.50 + Rs. 661.50

= Rs. 2184

2. Find:

(i) the lateral or curved surface area of a petrol storage tank that is 4.2 m in diameter and 4.5 m high.

(ii) how much steel was actually used if $\frac{1}{12}$ of the steel actually used was wasted in making the tank?

Ans. (i) Diameter of cylindrical petrol tank = 4.2 m

\therefore Radius of the cylindrical petrol tank = $\frac{4.2}{2} = 2.1 \text{ m}$

And Height of the tank = 4.5 m

\therefore Curved surface area of the cylindrical tank = $2\pi rh = 2 \times \frac{22}{7} \times 2.1 \times 4.5 = 59.4 \text{ m}^2$

(ii) Let the actual area of steel used be x meters



Since $\frac{1}{12}$ of the actual steel used was wasted, the area of steel which has gone into the tank.

$$= x - \frac{1}{12}x = \frac{11}{12}x$$

$$\therefore \frac{11}{12}x = 59.4$$

$$\Rightarrow x = 59.4 \times \frac{12}{11} = 64.8 \text{ m}^2$$

Hence steel actually used is 64.8 m^2 .

3. A hemispherical bowl made of brass has inner diameter 10.5 cm. Find the cost of tin-plating it on the inside at the rate of Rs. 16 per 100 cm^2 .

Ans. Inner diameter of bowl = 10.5 cm

$$\therefore \text{Inner radius of bowl } (r) = \frac{10.5}{2} = 5.25 \text{ cm}$$

Now, Inner surface area of bowl = $2\pi r^2$

$$= 2 \times \frac{22}{7} \times 5.25 \times 5.25$$

$$= 2 \times \frac{22}{7} \times \frac{21}{4} \times \frac{21}{4} = \frac{693}{4} \text{ cm}^2$$

\therefore Cost of tin-plating per 100 cm^2 = Rs. 16

$$\therefore \text{Cost of tin-plating per } 1 \text{ cm}^2 = \frac{16}{100}$$

$$\therefore \text{Cost of tin-plating per } \frac{693}{4} \text{ cm}^2 = \frac{16}{100} \times \frac{693}{4} = \text{Rs. } 27.72$$

4. The diameter of the moon is approximately one fourth the diameter of the earth. Find the ratio of their surface areas.

Ans. Let diameter of Earth = x

$$\therefore \text{Radius of Earth } (r) = \frac{x}{2}$$

$$\therefore \text{Surface area of Earth} = 4\pi r^2 = 4\pi \times \frac{x}{2} \times \frac{x}{2} = \pi x^2$$

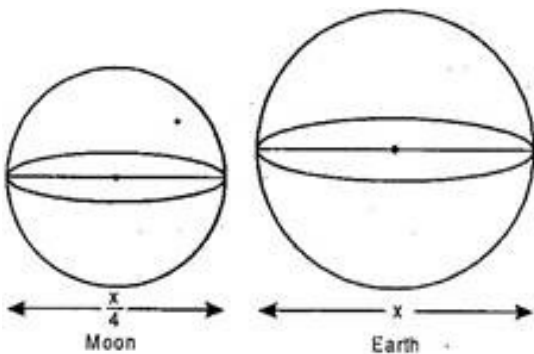

$$\text{Now, Diameter of Moon} = \frac{1}{4} \text{th of diameter of Earth} = \frac{x}{4}$$

$$\therefore \text{Radius of Moon } (r) = \frac{x}{8}$$

$$\text{Surface area of Moon} = 4\pi r^2 = 4\pi \times \frac{x}{8} \times \frac{x}{8} = \frac{\pi x^2}{16}$$

$$\text{Now, Ratio} = \frac{\text{Surface area of Moon}}{\text{Surface area of Earth}} = \frac{\frac{\pi x^2}{16}}{\pi x^2} = \frac{\pi x^2}{16} \times \frac{1}{\pi x^2} = \frac{1}{16}$$

\therefore Required ratio = 1: 16

5. A solid cube of side 12 cm is cut into eight cubes of equal volume. What will be the side of the new cube? Also, find the ratio between their surface areas.

$$\text{Ans. Volume of solid cube} = (\text{side})^3 = (12)^3 = 1728 \text{ cm}^3$$

According to question, Volume of each new cube = $\frac{1}{8}$ (Volume of original cube)

$$= \frac{1}{8} \times 1728 = 216 \text{ cm}^3$$

$$\therefore \text{Side of new cube} = \sqrt[3]{216} = 6 \text{ cm}$$

$$\text{Now, Surface area of original solid cube} = 6 (\text{side})^2$$

$$= 6 \times 12 \times 12 = 864 \text{ cm}^2$$

$$\text{Now, Surface area of original solid cube} = 6 (\text{side})^2$$

$$= 6 \times 6 \times 6 = 216 \text{ cm}^2$$

Now according to the question,

$$\frac{\text{Surface area of original cube}}{\text{Surface area of new cube}} = \frac{864}{216} = \frac{4}{1}$$

Hence required ration between surface area of original cube to that of new cube = 4: 1.

6. The volume of a right circular cone is 9856 cm^3 . If the diameter of the base is 28 cm, find:

(i) Height of the cone

(ii) Slant height of the cone

(iii) Curved surface area of the cone.

Ans. (i) Diameter of cone = 28 cm

$$\therefore \text{Radius of cone} = 14 \text{ cm}$$

$$\text{Volume of cone} = 9856 \text{ cm}^3$$

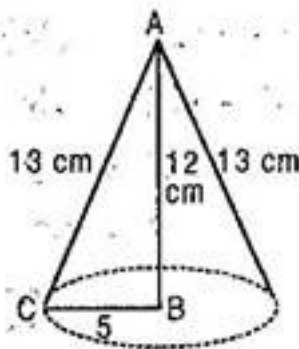
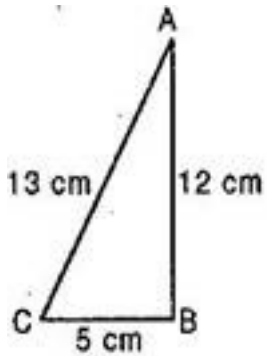
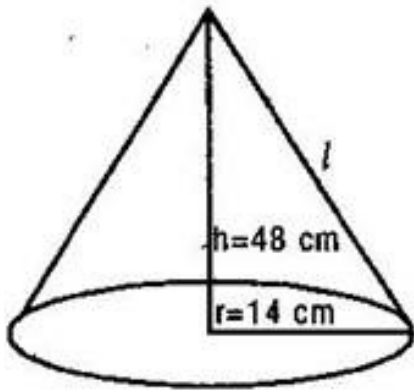

$$\Rightarrow \frac{1}{3} \pi r^2 h = 9856$$

$$\Rightarrow \frac{1}{3} \times \frac{22}{7} \times 14 \times 14 \times h = 9856$$

$$\Rightarrow h = \frac{9856 \times 3 \times 7}{22 \times 14 \times 14} = 48 \text{ cm}$$

(ii) Slant height of cone (l) = $\sqrt{r^2 + h^2}$

$$= \sqrt{(14)^2 + (48)^2} = \sqrt{196 + 2304}$$

$$= \sqrt{2500} = 50 \text{ cm}$$

(iii) Curved surface area of cone = $\pi r l$

$$= \frac{22}{7} \times 14 \times 50 = 2200 \text{ cm}^2$$

7. The front compound wall of a house is decorated by wooden spheres of diameter 21

cm, placed on small supports as shown in figure. Eight such spheres are used for this purpose and are to be painted silver. Each support is a cylinder of radius 1.5 cm and height 7 cm and is to be painted black. Find the cost of paint required if silver paint costs 25 paise per cm^2 and black paint costs 5 paise per cm^2 .

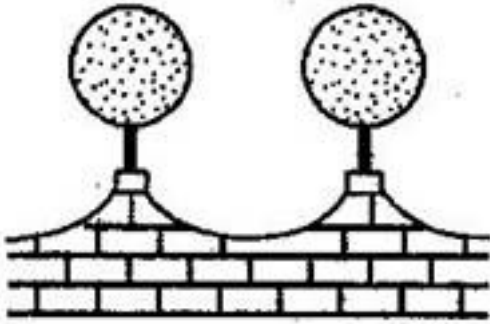

Ans. Diameter of a wooden sphere = 21 cm.

$$\therefore \text{Radius of wooden sphere (R)} = \frac{21}{2} \text{ cm}$$

And Radius of the cylinder (r) = 1.5 cm

Surface area of silver painted part = Surface area of sphere - Upper part of cylinder for support

$$= 4\pi R^2 - \pi r^2$$

$$= \pi(4R^2 - r^2)$$

$$= \frac{22}{7} \times \left[4 \times \left(\frac{21}{2} \right)^2 - \left(\frac{15}{10} \right)^2 \right]$$

$$= \frac{22}{7} \times \left[\frac{4 \times 441}{4} - \frac{9}{4} \right]$$

$$= \frac{22}{7} \times \left[\frac{1764 - 9}{4} \right]$$

$$= \frac{22}{7} \times \frac{1755}{4} = 1378.928 \text{ cm}^2$$

Surface area of such type of 8 spherical part = 8×1378.928

$$= 11031.424 \text{ cm}^2$$

∴ Cost of silver paint over 1 cm^2 = Rs. 0.25

∴ Cost of silver paint over 11031.928 cm^2 = 0.25×11031.928 = Rs. 2757.85

Now, curved surface area of a cylindrical support = $2\pi rh$

$$= 2 \times \frac{22}{7} \times \frac{15}{10} \times 7 = 66 \text{ cm}^2$$

Curved surface area of 8 such cylindrical supports = $66 \times 8 = 528 \text{ cm}^2$

∴ Cost of black paint over 1 cm^2 of cylindrical support = Rs. 0.50

∴ Cost of black paint over 528 cm^2 of cylindrical support = 0.50×528

$$= \text{Rs. } 26.40$$

∴ Total cost of paint required = Rs. 2757.85 + Rs. 26.4

$$= \text{Rs. } 2784.25$$

8. The difference between outside and inside surface of a cylindrical metallic tripe 14 cm. long is 44 sq cm. if the tripe is made of 99 cu cm. of metal, find the outer and inner radius of the tripe.

Ans. Let r_1 cm and r_2 cm can be the inner and outer radii respectively of the pipe

Area of the outside surface = $2\pi r_2 h$ sq unit

Area of the inside surface = $2\pi r_1 h$ sq unit

∴ By the given condition

$$2\pi r_2 h - 2\pi r_1 h = 44$$

$$\text{or } 2\pi h(r_2 - r_1) = 44$$

$$\therefore 2 \times \frac{22}{7} \times 14 \times (r_2 - r_1) = 44 (\because h = 14\text{cm})$$

$$\text{Or, } 88(r_2 - r_1) = 44$$

$$\therefore (r_2 - r_1) = \frac{1}{2} \quad (\text{i})$$

Again volume of the metal used in the pipe = $\pi(r_2^2 - r_1^2)h$ cu units

$$\therefore \frac{22}{7}(r_2^2 - r_1^2) \times 14 = 99 \text{ (given)}$$

$$\text{or, } 44(r_2^2 - r_1^2) = \frac{99}{4} = \frac{9}{4} \quad (\text{ii})$$

Dividing (ii) by (i) we get

$$\frac{(r_2^2 - r_1^2)}{r_2 - r_1} = \frac{9}{4} \div \frac{1}{2}$$

$$\text{Or, } r \frac{(r_2 - r_1)(r_2 + r_1)}{(r_2 - r_1)} = \frac{9}{4} \times \frac{2}{1}$$

$$\therefore (r_2 + r_1) = \frac{9}{2}$$

$$\text{Also, } (r_2 - r_1) = \frac{1}{2} \text{ [From (i)]}$$

$$2r_2 = 5$$

Adding

$$\therefore r_2 = \frac{5}{2}$$

$$\text{And, } \frac{5}{2} + r_1 = \frac{9}{2}$$



$$\therefore r_1 = \frac{9}{2} - \frac{5}{2}$$

$$\text{Or, } r_1 = 2$$

Thus outer radius = 2.5 cm

And inner radius = 2 cm

9. The ratio between the radius of the base and height of a cylinder is 2:3. find the total surface area of the cylinder if its volume is 1617 cm^3

Ans. Let the radius of the base of the cylinder be $2x$ cm.

\therefore Height of the cylinder = $3x$ cm.

Volume of the cylinder = $\pi r^2 h$ cu units

$$= \frac{22}{7} \times (2x)^2 \times 3x \text{ cu cm.}$$

$$= \frac{22}{7} \times 4x^2 \times 3x \text{ cu cm.}$$

$$= \frac{264}{7} x^3 \text{ cu cm}$$

\therefore by the given condition

$$\frac{264}{7} x^3 = 1617$$

$$x^3 = \frac{1617 \times 7}{264} = \frac{49 \times 7}{8} = \left(\frac{7}{2}\right)^3$$

$$\therefore x = \frac{7}{2}$$

or

$$\text{Thus radius} = 2 \times \frac{7}{2} = 7 \text{ cm.}$$

$$\text{And height} = 3 \times \frac{7}{2} = \frac{21}{2} \text{ cm.}$$



Total surface area = $2\pi r(r+h)$ sq units

$$= 2 \times \frac{22}{7} \times 7 \times \left(7 + \frac{21}{2}\right) \text{ sq cm.}$$

$$= 44 \times \frac{35}{2} \text{ sq cm.}$$

= 770 sq cm.

thus total surface area of the cylinder = 770 sq cm.

10. Twenty-seven solid iron spheres, each of radius r and surface area S are melted to form a sphere with surface area S' find the

(i) radius r' of the new sphere

(ii) ratio of S and S'

Ans. Total volume of 27 iron spheres = Volume of new sphere

$$\text{Volume of each original sphere} = \frac{4}{3} \pi r^3$$

$$\text{Volume of 27 spheres} = 27 \times \frac{4}{3} \pi r^3 = \frac{108}{3} \pi r^3$$

$$\text{Volume of new sphere} = \frac{108}{3} \pi r^3$$

$$\frac{4}{3} \pi (r')^3 = \frac{108}{3} \pi r^3$$

$$(r')^3 = \frac{108}{3} \pi r^3 \times \frac{3}{4\pi}$$

$$= 27r^3$$

$$(i) \quad r' = 3r$$

$$(ii) \quad \text{Surface area of original sphere } (S) = 4\pi r^2$$

$$\text{Surface area of new sphere } (S') = 4\pi (r')^2$$

$$= 4\pi (3r)^2$$

$$= 36\pi r^2$$

$$\therefore \text{Ratio of } S \text{ and } S' = \frac{4\pi r^2}{36\pi r^2} = \frac{1}{9}$$

$$= 1 : 9$$

11. Shanti sweets stall was placing an order for making cardboard boxes for packing their sweets two sizes of boxes were required. The bigger of dimensions $25\text{cm} \times 20\text{cm} \times 5\text{cm}$ and the smaller of dimensions $15\text{cm} \times 12\text{cm} \times 5\text{cm}$ for all the overlaps, 5% of the total surface area is required extra. If the cost of cardboard is Rs 4 for 1000cm^2 . Find the cost of cardboard required for supplying 250 boxes of each kind.

Ans. Given dimensions of bigger box

$$= 25\text{cm} \times 20\text{cm} \times 5\text{cm}$$

Total surface area of bigger box

$$= 2[25 \times 20 + 20 \times 5 + 25 \times 5]\text{cm}^2$$

$$= 2[500 + 100 + 125]\text{cm}^2 = 2 \times 725 = 1450\text{cm}^2$$

Extra cardboard for packing = 5% of 1450cm^2

$$= \frac{5}{100} \times 1450 = 72.5\text{cm}^2$$

Cardboard used for making box = $1450 + 72.5 = 1522.5\text{cm}^2$

Dimensions of smaller box = $15\text{cm} \times 12\text{cm} \times 5\text{cm}$

Total surface area of smaller box = $2[15 \times 12 + 12 \times 5 + 15 \times 5]\text{cm}^2$

$$= 2[180 + 60 + 75]\text{cm}^2$$

$$= 2 \times 315\text{cm}^2 = 630\text{cm}^2$$

Extra cardboard for packing = 5% of 630

$$= \frac{5}{100} \times 630 = 31.5\text{cm}^2$$

Total area of cardboard = $630 + 31.5 = 661.5\text{cm}^2$

Total cardboard used for making 2 boxes

$$= (1522.5 + 661.5)\text{cm}^2 = 2184\text{cm}^2$$

Cardboard used for making 250 boxes = $250 \times 2184 = 546000\text{cm}^2$

$$\text{Cost of cardboard} = \frac{4}{1000} \times 546000 = \text{Rs. } 2184$$

12. A hollow spherical shell is made of a metal of density 9.6 g/cm^3 . The external diameter of the shell is 10cm and its internal diameter is 9 cm. Find

(i) Volume of the metal contained in the shell

(ii) Weight of the shell.

(iii) Outer surface area of the shell.

Ans. External diameter of the spherical shell = 10cm

$$\therefore \text{External radius } R = 5 \text{ cm}$$

Internal diameter = 9cm

$$\text{Internal radius} = \frac{9}{2} \text{ cm}$$

$$r = \frac{9}{2} \text{ cm}$$

$$\text{(i) Volume of the metal} = \frac{4}{3} \pi [R^3 - r^3] \text{ cm}^3$$

$$= \frac{4}{3} \pi \left[5^3 - \left(\frac{9}{2} \right)^3 \right] \text{ cm}^3$$

$$= \frac{4}{3} \times \frac{22}{7} \left[125 - \frac{729}{8} \right] \text{ cm}^3$$

$$= \frac{88}{21} \times \frac{271}{8} \text{ cm}^3 = 141.95 \text{ cm}^3$$

(ii) Weight of the shell = Volume \times density

$$= 141.95 \text{ cm}^3 \times 9.6 \text{ gm/cm}^3$$

$$= 1363 \text{ gm}$$

$$= 1.363 \text{ kg}$$

$$\text{(iii) Outer surface area} = 4\pi r^2$$

$$\begin{aligned} &= 4\pi(5)^2 \\ &= 4 \times \frac{22}{7} \times 25 \\ &= \frac{2200}{7} = 314.389 \text{ cm}^2 \end{aligned}$$

